



# UNIVERSAL CONTROL SERIES

## Models

**UZ3, UZ4, UZ6**  
Universal Control

**EZ3, EZ1**  
Expansion Module

## INSTALLATION, OPERATION & MAINTENANCE MANUAL

UZ3, UZ4, UZ6

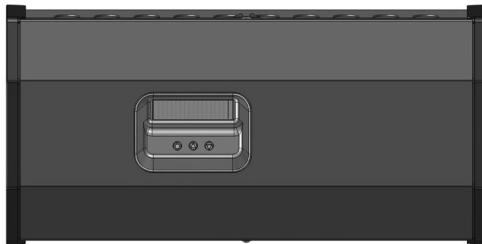

EZ3



EZ1



**ECR** international

Manufactured by:  
ECR International Inc.  
2201 Dwyer Avenue, Utica, NY 13501  
Tel. 800 253 7900  
[www.ecrinternational.com](http://www.ecrinternational.com)  
PN 240010923 REV. F [07/01/2018]

# TABLE OF CONTENTS

1 - Important Safety Information.....	2
2 - Product Description And Features.....	3
3 - Mounting .....	4
4 - Electrical Specifications, Dimensions And Wiring Connections.....	5
5 - User Interface.....	12
6 - Control Configuration .....	13
7 - Sequence Of Operation.....	15
8 - Troubleshooting.....	19-20
9 - Replacement Parts.....	20
10 - Technical Support .....	20

## 1 - IMPORTANT SAFETY INFORMATION

***Become familiar with symbols identifying potential hazards.***



This is the safety alert symbol. Symbol alerts you to potential personal injury hazards. Obey all safety messages following this symbol to avoid possible injury or death.

### **General**

Installation shall be completed by qualified agency.

### **⚠ DANGER**

Indicates a hazardous situation which, if not avoided, WILL result in death or serious injury

### **⚠ WARNING**

Indicates a hazardous situation which, if not avoided, could result in death or serious injury.

### **⚠ CAUTION**

Indicates a hazardous situation which, if not avoided, could result in minor or moderate injury.

### **NOTICE**

Used to address practices not related to personal injury.

### **⚠ WARNING**

Fire, explosion, asphyxiation and electrical shock hazard. Improper installation could result in death or serious injury. Read this manual and understand all requirements before beginning installation.

**Information and specifications outlined in this manual in effect at the time of printing of this manual. ECR International, Inc. reserves the right to discontinue, change specifications or system design at any time without notice and without incurring any obligation, whatsoever.**

## **2 - PRODUCT DESCRIPTION AND FEATURES**

### **Product Description**

The Argo Universal Control provides individual control for comfort heating, domestic hot water along with many other residential hot water applications.

The Universal Control can control any combination of zone pumps or zone valves in a single control module unit without need for specific add on modules.

The Universal Control can also utilize up to three heating sources or three separate temperature settings and control up to 15 heating zones independently. Features such as zone priority, post purge and zone staggering are all standard features on the Argo Universal Control.

### **Features**

#### **1. Models**

- **Master controls**

- UZ3 Three Zone Control
- UZ4 Four Zone Control
- UZ6 Six Zone Control

- **Expansion Modules**

- EZ1 One Zone
- EZ3 Three Zone

#### **2. Hardware**

##### **Master Controls**

- LCD display 2-line, 16 character, 5x7 dot matrix
- Three button User Interface
- Three programmable XX terminals for boiler and temperature control
- ZR/ZC terminals
- Connection for ECR's DPM-2 Outdoor reset control

##### **All Controls**

- Plug and Play expandability port
- Three wire thermostat compatible (R, C, W)
- High Volt circuit - Overcurrent protection ( 12 A or 8 A fuse)
- High Volt circuit - Brown out, transient and surge protection
- Low Volt circuit - Circuit protection
- Terminals for 115 Vac field power, boiler and zone pump connections
- Terminals for 24 Vac zone valve connections
- Transformer, remote mounted, QC connections, 30 VA (1-zone), 40 VA (3-zone) and 75 VA (4 & 6 zone)
- Non-Volatile memory

### **3. Firmware**

- Priority with selectable timer setting
- ZR/ZC with selectable active/non active setting
- Error codes display
- Pump exercising with selectable settings
- Non-Volatile memory storage
- Zone configuration setting (valve or pump)
- Three programmable XX terminals for boiler and temperature control
- Power monitoring (Fault <18Vac, >33 Vac)
- Zone staggering delay
- Test feature - Exercises all control functions to confirm control operation
- Zone pump and primary pump post purge
- Zone expandability, up to 15 zones
  - Three Zone UZ3 Control - 12 zones
  - Four Zone UZ4 Control - 13 zones
  - Six Zone UZ6 Control - 15 zones

## **3 - MOUNTING**

### **Mounting Instructions**

- Mount Argo UZ and EZ Controls vertically on solid wall or partition.
- Mount control as close as possible to device to be controlled, for your convenience.
- Do not mount Argo UZ and EZ Controls more than 75 feet away from pumps, valves and thermostats.
- Select location easily accessible for installation and service.

#### **Note**

Place rubber or felt washers between case and mounting surface to reduce possible transformer hum and relay noise amplified by mounting surfaces such as metal, plasterboard, and other similiar materials.

1. Position control. Mark mounting holes.
2. Start screws (not provided) for keyhole type mounting holes in upper corner(s). Tighten screws to 1/8" (3mm) from surface.
3. Hang control on screw(s), position case, and start bottom screws.
4. Tighten all screws.

## **4 - ELECTRICAL SPECIFICATIONS, DIMENSIONS AND WIRING CONNECTIONS**

### **WARNING**

Electrical shock hazard. Turn OFF electrical power supply at service panel before making electrical connections. Failure to do so could result in death or serious injury.

#### **Electrical Specifications and Wiring**

- A. Installation shall be in accordance with authority having jurisdiction. In absence of such requirements:
  - USA - National Electrical Code, ANSI/NFPA 70. Wiring shall be National Electrical Code Class 1.
  - Canada - Canadian Electrical Code, Part 1, CSA C22.1: Safety Standard for Electrical Installations. Wiring shall be Canadian Electrical Code, Part 1, CSA C22.1.
- B. Shall use copper conductors only
- C. All primary wiring shall be 14 AWG minimum.
- D. All Class 2 low volt wiring shall be 18 AWG min.
- E. Torque terminal screws 6 to 7 inch pounds.

## 4 - ELECTRICAL SPECIFICATIONS, DIMENSIONS AND WIRING CONNECTIONS

### Electrical Specifications, Dimensions and Wiring Connections

#### 1. Electrical Specification

<b>TABLE 1</b>	
<b>Line Voltage Power Connections in Accordance with NEC/CEC and Local Codes</b>	
<b>Use Copper Conductors Only</b>	
<b>LINE</b>	Field Power Supply, 115Vac, 50/60Hz, 1-ph, 15A Max UZ3, EZ3, EZ1, 20A Max UZ4 and UZ6
L, N	
<b>PRIMARY PUMP</b>	Provides Power to Boiler (System/Primary) Pump 115Vac, 50/60Hz, 1-Ph Rated 7.2FLA, 1/3 hp. Maximum Allowable Pump
L, N, G	
<b>ZONE PUMPS</b>	Provides Power to Zone Pump(s) 115Vac, 50/60Hz, 1-Ph Rated 7.2FLA, 1/3 hp. Maximum Allowable Pump
L, N, G	
<b>ZR/ZC</b>	115Vac, 50/60Hz, 1-Ph, Connection to boiler limit control ZR/ZC for tank-less coil applications
<i>Note: Total combined load of all pumps must be less than 12A for UZ3, EZ3, 7.2A for EZ1, 20A for UZ4 and UZ6</i>	
<b>Low Voltage Connections (NEC Class 2)</b>	
$T_R, T_W, C$	Heating, CH, DHW – Thermostat Connection, 24Vac (R, W, C), 4VA Max Dry Contact Close TR-TW Activation of zone valve or pump 24Vac Between TR - C
1, 2, 3, 4	Zone Valve Connections, 24Vac, 24VA Max Terminals 1 – 2, Zone Valve Power Connection Terminals 3 - 4 , Zone Valve End Switch Connection
<i>Note: Total combined load for all valves and thermostats must be less than 40VA for UZ3, EZ3, 24VA for EZ1, 75VA for UZ4 and UZ6</i>	
XX - 1	Dry Contact, Connect to Boiler TT terminals (CH), Rated 24Vac, 2A
XX - 2	Dry Contact, Connect to Boiler TT terminals (CH-2), Rated 24Vac, 2A
XX - 3	Dry Contact, Connect to Boiler TT terminals (DHW), Rated 24Vac, 2A
Expansion Port	Connection for Expansion Module, RJ45

# 4 - ELECTRICAL SPECIFICATIONS, DIMENSIONS AND WIRING CONNECTIONS

Figure 1 - Dimensions and Mounting

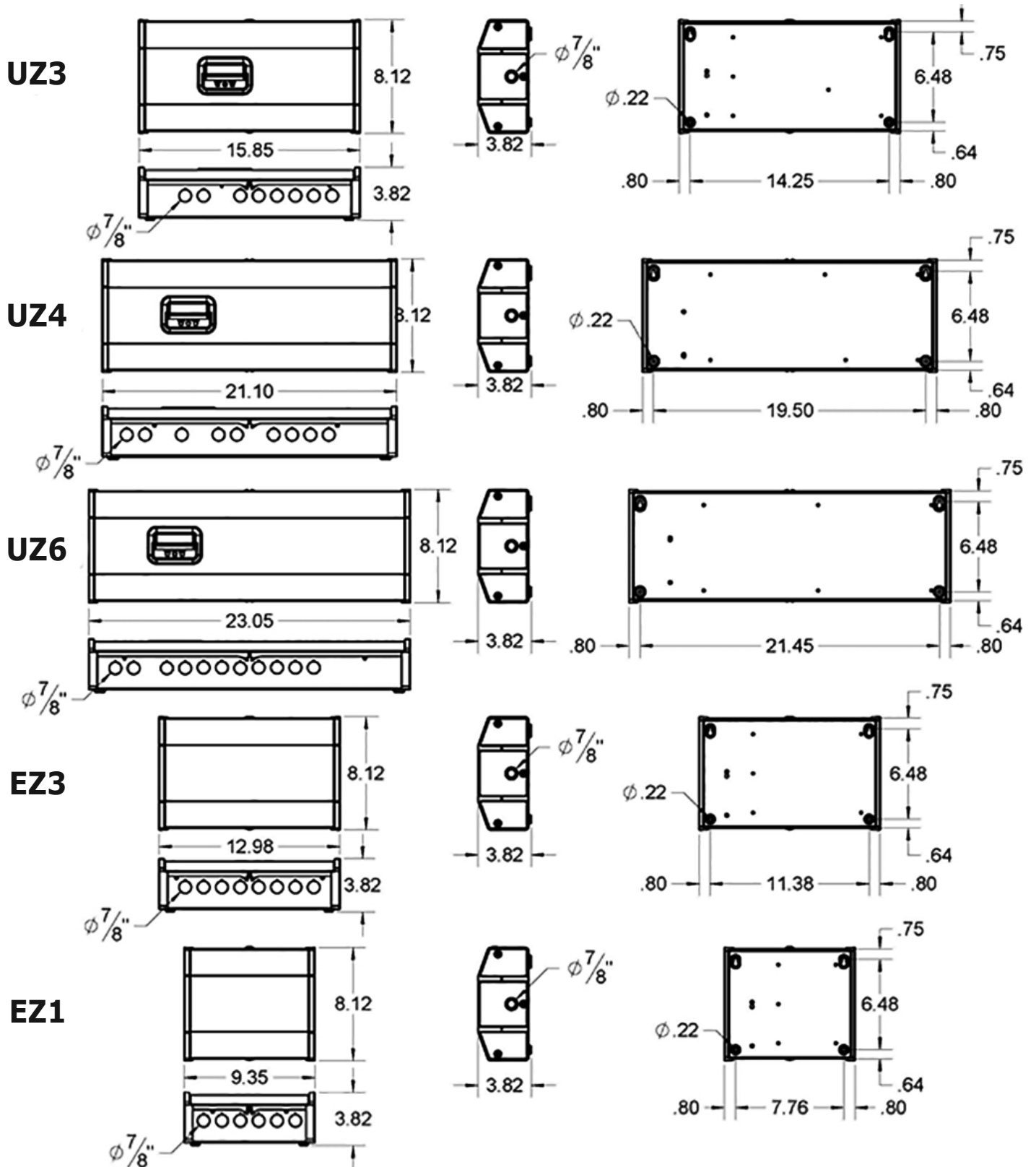

# 4 - ELECTRICAL SPECIFICATIONS, DIMENSIONS AND WIRING CONNECTIONS

Figure 2 - Control Wiring - UZ3

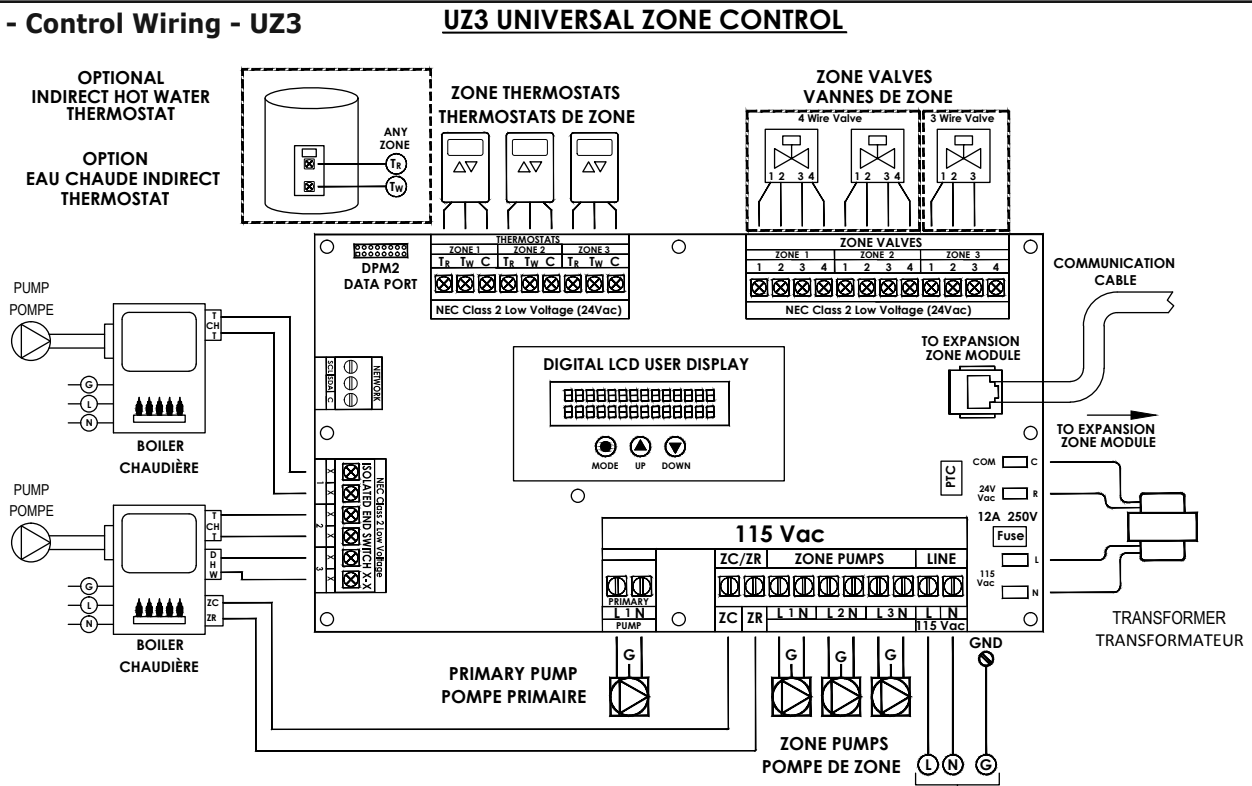
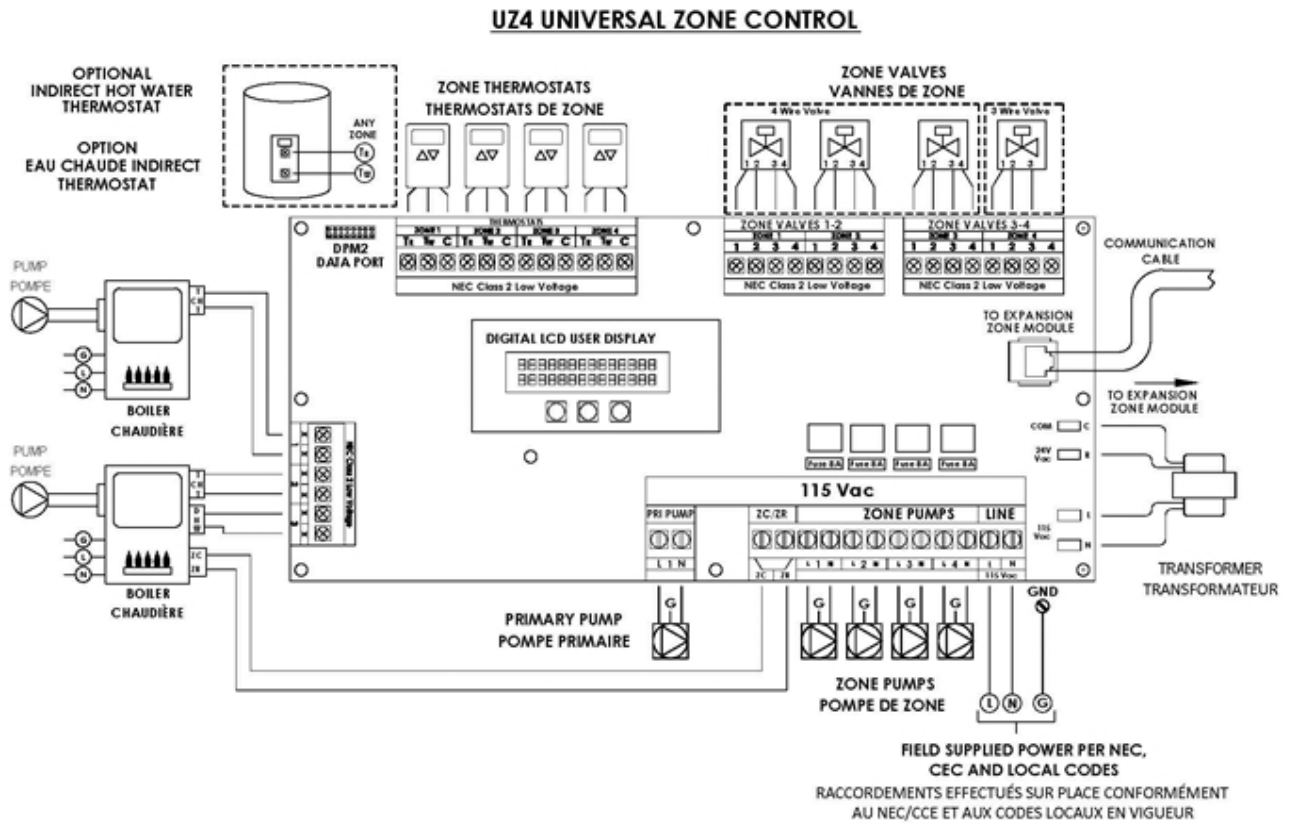

Figure 3 - Control Wiring - UZ4





# 4 - ELECTRICAL SPECIFICATIONS, DIMENSIONS AND WIRING CONNECTIONS

Figure 4 - Control Wiring - UZ6

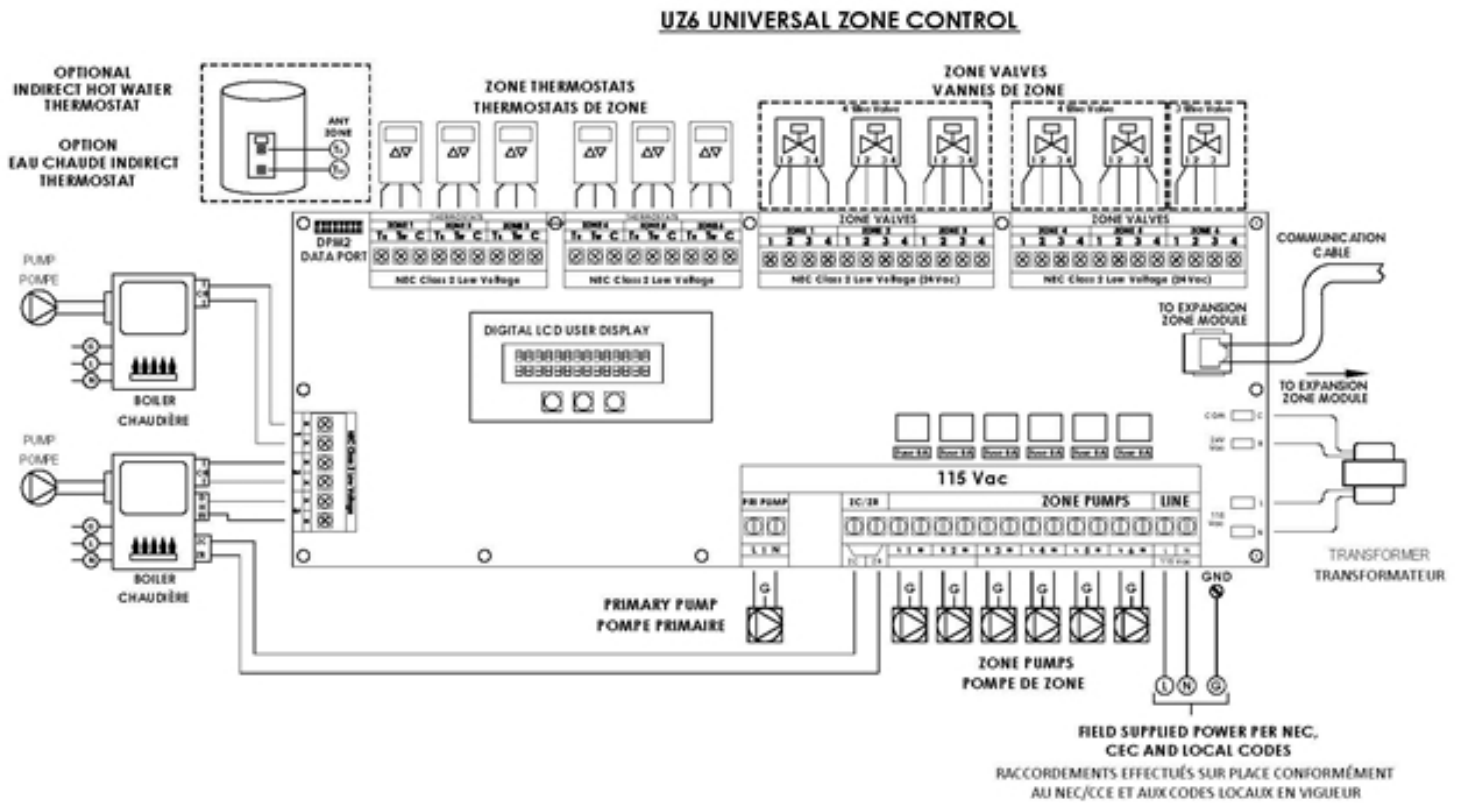

# 4 - ELECTRICAL SPECIFICATIONS, DIMENSIONS AND WIRING CONNECTIONS

Figure 5 - Control Wiring - EZ3

## EZ3 EXPANSION MODULE, 3-ZONE

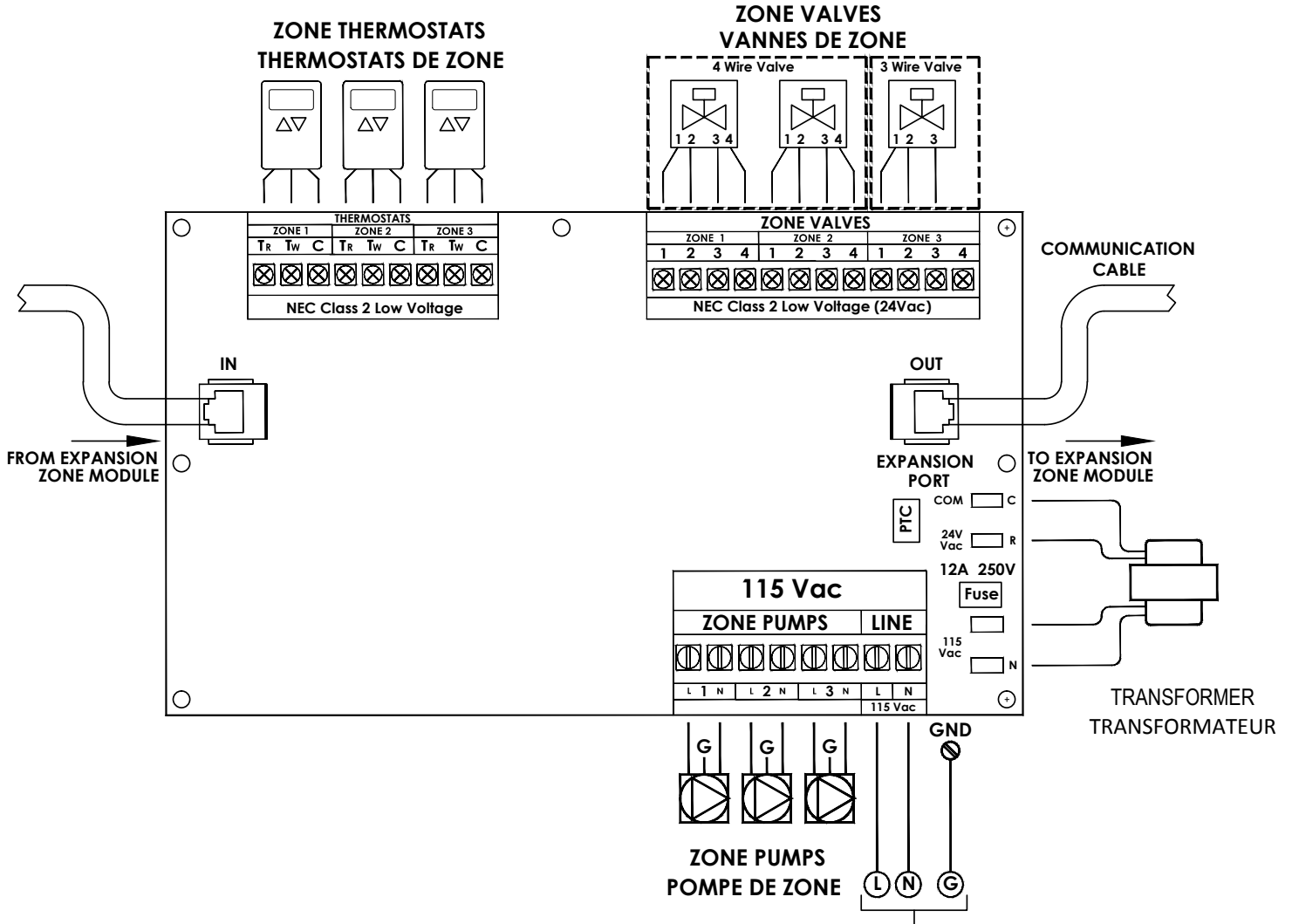

# 4 - ELECTRICAL SPECIFICATIONS, DIMENSIONS AND WIRING CONNECTIONS

Figure 6 - Control Wiring - EZ1

## EZ1 EXPANSION MODULE, 1-ZONE

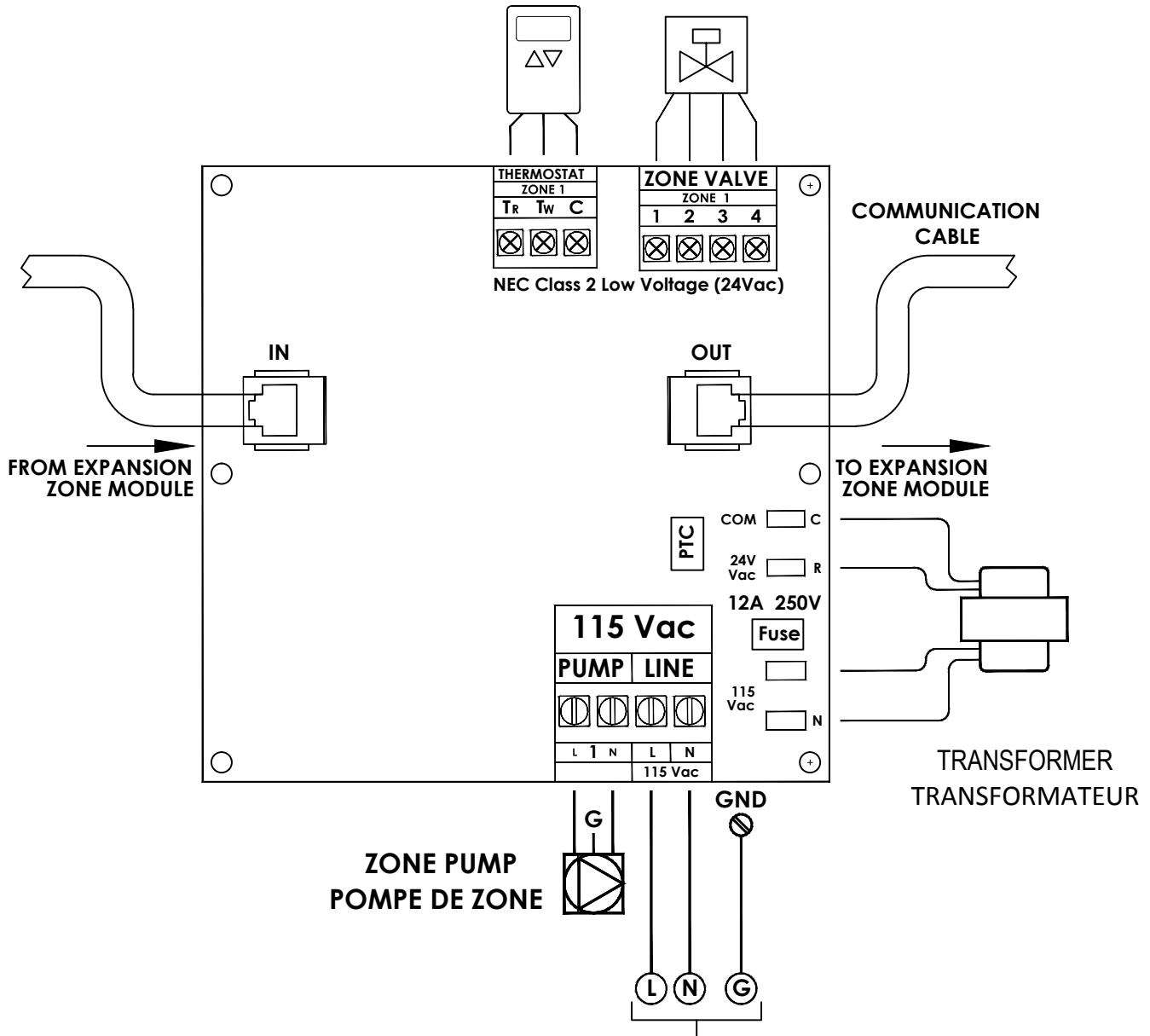

**FIELD SUPPLIED POWER PER NEC,  
CEC AND LOCAL CODES**

RACCORDEMENTS EFFECTUÉS SUR PLACE CONFORMÉMENT  
AU NEC/CCE ET AUX CODES LOCAUX EN VIGUEUR

## 5 - USER INTERFACE

### User Interface

#### 1. Digital LCD User Display And Interface

- A. Configuration Selection Button – Selects control configuration. Press once to view zone status. Hold to enter test mode.
- B. LCD Display. Indicates configuration zone status and error codes.
- C. Up and Down Adjustment Buttons – Press up arrow once to view configuration settings. Press up and down arrow buttons to access configuration mode. In configuration mode, used to select settings.

Figure 7 - User Interface Display

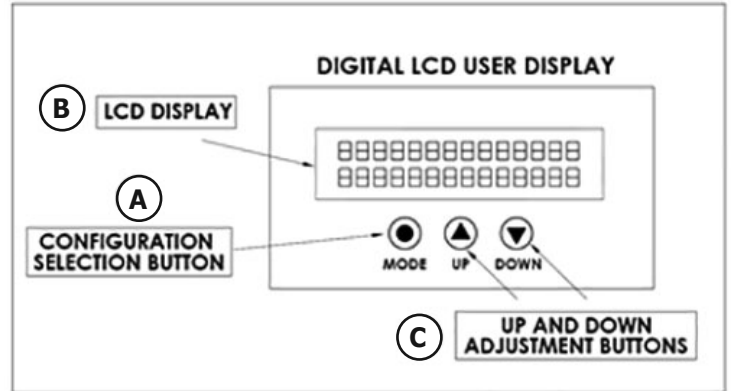

## **6 - CONTROL CONFIGURATION**

### **Control Configuration**

#### **1. Zone configuration, Pump or Valve**

Use user interface menu to configure zone status for pump or valve operation. Configuration method applies to main control and all expansion modules.

- Pump (Default)
- Valve

#### **2. Configuration Menu**

Press the up arrow to view the configuration settings

To enter configuration mode press up and down arrow buttons for 5 seconds.

- Press mode button to scroll selections.
- Press up or down arrow to change settings.
- To exit configuration mode press up and down arrow for 1 second or leave idle 2 minutes.

#### **3. Control Configuration Programming**

- A. Priority – Used to give exclusive operation to selected zones (XX #3)

On – When priority zone is energized zones will be deactivated for the selected priority time.

Off – All zones will activate/de-activate equally.

Isolated End Switch – XX #3 is the priority end switch. Any zone assigned to XX #3 will be given priority status when priority is on.

- B. Primary pump – Used to control primary pump in conjunction with priority zones. Not available when priority is set to off.

Active - The primary pump will energize with a priority call.

Inactive - The primary pump will not energize with a priority call.

- C. Priority Timer – Sets the maximum priority time. When the time expires priority will be suspended for an equal time period. Selections – Off, 30m, 45m, 60m, 75m, 90m.

- D. End Switch Assignment – Assigns isolated end switches (XX) to zones.

End switch selections are 1, 2, 3.

End switch 3 (XX) is the priority end switch. Any zone assigned to XX # 3 will be given priority status. (Priority switch must be set to on.)

- E. ZR/ZC Activation – Used to delay all pumps from operating until boiler reaches minimum temperature.

Selection – On or Off

On – All pumps remain off until ZR/ZC is closed\*.

Off – Pumps are not dependent on ZR/ZC status.

\* For valve configuration, zone terminals 3&4 must also be closed for primary pumps to energize.

- F. Post Purge (Purge Timer) – Allows extended zone and primary pump operation after zone call ends. Not available if ZR/ZC is active.

Selections – Off, 15m, 30m, 45m, 60m, 75m.

- G. Purge To Assignment – Selects the target zone for purging.

Selections – Any zone 1, 2, 3... or Last Call.

- H. Pump Exercising – Used to prevent pump seizure due to periods of inactivity.

Selections – 1, 7 or 30 days.

Pump Exercising is not available if ZR/ZC is ON.

## 6 - CONTROL CONFIGURATION

### 4. Expansion Port

The expansion port (RJ45 connection) is used to connect expansion modules to the control. A low voltage communication connect cable is provide with the expansion module. Each expansion module is independently powered and does not require valve or pump power from the main controller.

Once connected the expansion module will be recognized by the main controller. Programming of the expansion module will occur through the main control.

<b>TABLE 2 - Configuration Menu</b>		
Press up and down arrow buttons to access (5 seconds) Then press up or down arrow button to change selection		
Configuration Setting	Display	Default
Zone 1, 2, 3 ...	Pump/Valve	Pump
Priority	On/Off	Off
* Primary Pump	Active/Inactive	Active
* Priority Timer	Off, 30, 45, 60, 75, 90 minutes	30m
Zone 1, 2, 3... End Switch	1, 2, 3	1 (All)
ZR/ZC	On/Off	Off
** Purge Timer	Off, 15s, 30s, 45s, 60s, 75s	Off
*** Purge To	Last Call, Zone 1, 2, 3, ....	Last Call
#Pump Exercising	Off, 1 Day, 7 Days, 30 Days	Off
<b>Zone Configuration</b>		
Press Mode Button to View (Pump or Valve)		
Configuration Setting	Display	Default
Zone Configuration	1,2,3,4... V-Valve, P-Pump	P-Pump (jumper installed)
* Primary pump and priority timer are not available if priority is Off		
** Purge Timer is not available if ZR/ZC is On		
*** Purge To is not available if purge timer is Off		
# Pump Exercising is not available if ZR/ZC is On		

## **7 - SEQUENCE OF OPERATION**

### **Sequence Of Operation**

#### **1. Thermostat call for Heat**

Field wired thermostats are connected to the designated NEC Class 2 low volt zone thermostat terminals designated TR, TW, C. The control is compatible with either two or three wire thermostats. The heating zone thermostat will connect TR and TW energizing the corresponding zone valve, zone pump and primary pump terminals. The designated Isolated End Switch XX terminals will close energizing the heat source (ie Boiler or HW valve).

Note: Activation of XX terminals is dependent on the programming sequence in the configuration menu.

Note: Primary pump is also dependent on ZR/ZC configuration.

#### **2. Zone Valve Output**

Zone valves are wired to designated zone valve terminals. The control is compatible with two, three or four wire zone valves. Power to the valve is provided through terminals 1&2. The end switch is connected to terminals 3&4 for a four-wire valve or terminal 3 for a three-wire valve.

Note: If a 2-wire zone valve is used, then a jumper wire should be placed across terminals 3 and 4 of the corresponding zone valve.

When the zone thermostat connects terminals TR and TW the control will provide 24Vac across terminals 1 and 2 of the corresponding zone valve terminals. When the zone valve end switch closes power will also be supplied to the primary pump terminals of the master control.

Note: Refer to the valve manufactures instructions for operation and wiring.

The configuration setting for ZR/ZC (Off/On) and Primary Pump (Active/Inactive) will also affect pump operation. Refer to control configuration programming.

The status of ZR/ZC (Off or On) will affect operation the primary pump. If "Off" the primary pump is not dependent on ZR/ZC connection.

If "On", a closed connection on terminals ZR/ZC (115V power to ZC) allows the primary pump to energize after zone terminals 3 & 4 close. An open connection (115V power removed from ZC) will prevent the primary pump from energizing.

The operation of the primary pump for the priority zone is also dependent on the primary pump selection made in the configuration menu (Active or Inactive). If "Active", the primary pump will energize with the priority zone. If "Inactive", the primary pump will not energize with the priority zone.

#### **3. Zone Pump Output**

Zone pumps are wired to the designated zone pump terminals. When the zone thermostat connects terminals TR and TW the control will provide 115Vac across terminals L and N of the corresponding zone and the primary pump terminals of the master control.

Note: Refer to the pump manufactures instructions for operation and wiring.

The configuration setting for ZR/ZC (Off/On) and Primary Pump (Active/Inactive) will also affect the pump operation. Refer to control configuration programming.

The status of ZR/ZC (Off or On) will affect operation of all pump outputs. If "Off" pump operation is not dependent on ZR/ZC connection.

If "On", a closed connection on terminals ZR/ZC (115V power to ZC) allows all pumps to energize. An open connection (115V power removed from ZC) will prevent all pumps from energizing.

The operation of the primary pump for the priority zone is also dependent on the primary pump selection made in the configuration menu (Active or Inactive). If "Active", the primary pump will energize with the priority zone. If "Inactive", the primary pump will not energize with the priority zone.

#### **4. Priority**

Priority operation allows selected zone(s) to have exclusive operation over other zones for a designated time period. For priority operation, priority must be set to "On" in the configuration menu. Multiple zones may be designated priority. Priority times are selectable, 30m, 45m, 60m, 75m, 90m or Off.

When a priority call exists for the selected time the control will then revert to non-priority operation for an equal time period until the priority call ends. Non-priority and priority zones will not operate simultaneously.

For priority operation the selected zone(s) must be assigned to Isolated End Switch XX #3. Zone(s) assigned to Isolated End Switch #3 will be given priority over all other zones. (Priority must be set to on).

## 7 - SEQUENCE OF OPERATION

### 5. End Switch Assignment (XX)

The main controller is equipped with three independent, isolated, dry contact end switches (XX-1, XX-2, XX-3) for energizing heat sources. End switches can be assigned to any zone and will close on a call for heating. End switch assignment is set through the control configuration programming menu.

When priority is set to on, end switches XX-1 and XX-2 are then designated as comfort heating zones. End switch XX-3 is then designated as the priority zone end switch. Any zone(s) assigned to end switch XX-3 will be treated as priority zone(s). When priority zone(s) call for heat, all other zones will not be allowed to operate until the priority time has expired or all non-priority zones are satisfied.

### 6. Primary Pump

The primary pump connection is located on the master control and is to be connected to the boiler pump.

Note: The primary pump may be connected to the boilers temperature control however, features such as post purge and primary pump active/inactive cannot be utilized.

When any zone thermostat connects terminals TR and TW the control will provide power to the primary pump terminals

If the zone is configured for pump operation the primary pump will energize immediately. If the zone is configured for valve operation the primary pump will energize when the end switch closes contact between 3&4.

Note: Refer to the pump manufacturer's instructions for operation and wiring.

Note: If a two(2) wire zone valve is used then a jumper wire should be placed across terminals 3 & 4 of the corresponding zone.

***The configuration setting for ZR/ZC (Off/ON) and Primary Pump (Active/Inactive) will also affect the pump operation. Refer to control configuration programming.***

### 7. ZR/ZC input

Used for tank-less coil applications to delay zone and primary pumps from energizing.

When activated, open ZR/ZC contacts will delay pumps.

Closed ZR/ZC contacts allows all pumps to energize.

**TABLE 3 - ZR/ZC Input, Zone Valve Operation**

Configuration		Input			Output		
Zone Config	ZR/ZC	R - W	ZR/ZC	Valve 3&4	Zone Pump/Valve	XX	Primary Pump
Valve	off	open	open/closed	op/cl	off	open	off
		closed		open	on	open	off
				closed	on	closed	on
Valve	on	open	op/cl	op/cl	off	open	off
		closed	open	op/cl		off	open
			ZC-N, 115 Vac	open	on	open	off
			ZC-N, 115 Vac	closed	on	closed	on

**Table 4 - ZR/ZC Input, Zone Pump Operation**

Configuration		Input			Output		
Zone Config	ZR/ZC	R - W	ZR/ZC	Valve 3&4	Zone Pump/Valve	XX	Primary Pump
Pump	off	open	op/cl	n/a	off	open	off
		closed	op/cl	n/a	on	closed	on
Pump	on	open	op/cl	n/a	off	open	off
		closed	open	n/a	off	open	off
		closed	ZC-N, 115 Vac	n/a	on	closed	on



## 7 - SEQUENCE OF OPERATION

### ZR/ZC Summary Operation

#### **A. Valve Configuration**

1. Thermostat  $T_{R-TW}$  closes, checks ZR/ZC state
2. Boiler temperature controller closes ZR/ZC, turns on zone valve/pump
3. Zone valve end switch closes 3 & 4, turns on XX and primary pump

#### **B. Pump Configuration**

1. Thermostat R-W closes, checks ZR/ZC state
2. Boiler temperature controller closes ZR/ZC (115V to ZC), turns on XX, zone valve/pump and primary pump.

**Note:** Pump Exercising is not available if ZR/ZC is On.

#### **8. Post Purge (Purge Timer)**

Post purge operation will continue to energize the primary pump, zone pumps and zone valves at the end of a heat call for improved system efficiency. All zones must be satisfied and ZR/ZC must be set to off for post purge to be activated.

Post purge times are selectable off (default), 15s, 30s, 45s, 60s, 75s.

Any zone may be selected and designated as the post purge target zone. The default target zone is the last zone to satisfy.

#### **9. Pump Exercising**

Pump exercising will energize zone and primary pumps to help avoid pump seizure due to prolong periods of inactivity. Exercising interval is based on the amount of inactive time for each pump. The interval selections available are off, 1, 7 and 30 days. Any pump that has not energized for the selected time period will energize for 30s Exercising will take place one at a time and not simultaneously. Zone staggering delay applies to pump exercising.

Pump Exercising is not available if ZR/ZC is On.

#### **10. Expansion Port**

An Expansion port is provided for controlling additional zones. Up to 15 zones may be controlled (maximum 3 expansion modules) with the addition of expansion modules. Control of XX terminals, boiler pump terminals, and ZR/ZC input terminals resides in main controller.

Each control, main controller and expansion module is powered independently and contains individual control transformers. Each expansion module is independently powered and does not require valve or pump power from the main controller.

Once connected programming selections in master controller will be extended to the expansion module including priority, ZR/ZC control, pump exercising and purge selections.

#### **11. DPM-2 Controller Port**

A communication port is provided through the 16-pin data port for connection to Argo's DPM-2 Fuel Economize, figure 6. The DPM-2 provides boiler set-back functionality regulating the boiler water supply temperature according to the outdoor ambient temperature. For more information on DPM-2 operation visit Argo's website at <http://www.argocontrols.com/>

**Table 5 - Universal Control and Expansion Modules**

Model	Zones	Maximum Zone capacity (w/Master)	Maximum allowable expansion modules
UZ3	Three (3)	12 Zones	Three (3)
UZ4	Four (4)	13 Zones	Three (3)
UZ6	Six (6)	15 Zones	Six (6)
Expansion modules			
EZ1	One (1)	na	na
EZ3	Three (3)	na	na

Note: The maximum number of expansion modules for UZ3 is three (3).

# 7 - SEQUENCE OF OPERATION

Figure 6 - DPM - 2 Wiring

TYPICAL WIRING APPLICATION USING DPM-2  
OUTSIDE RESET WITH ARGO UZ-3  
CIRCULATOR CONTROL

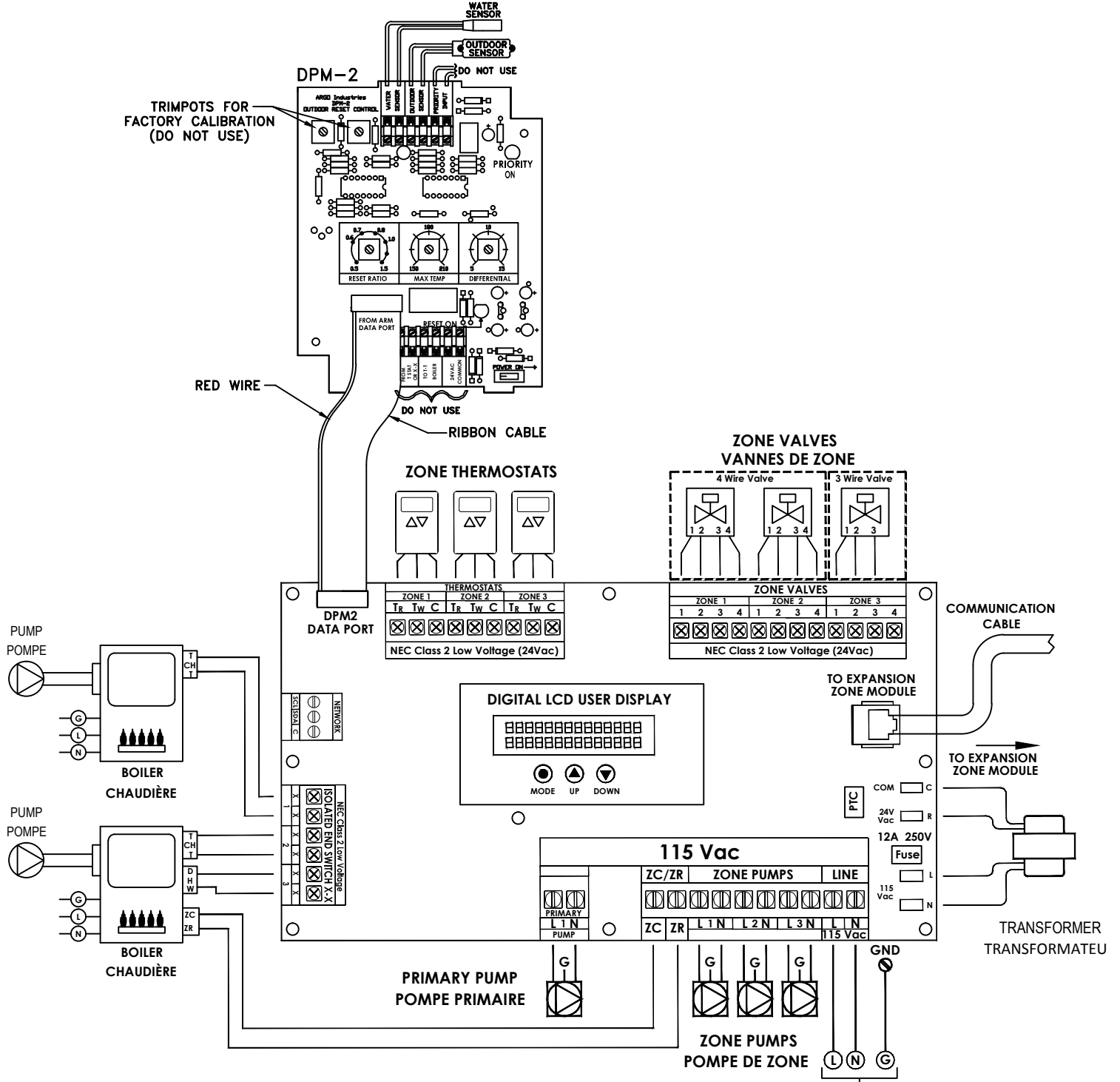

FIELD SUPPLIED POWER PER NEC,  
CEC AND LOCAL CODES  
RACCORDEMENTS EFFECTUÉS SUR PLACE CONFORMÉMENT  
AU NEC/CCE ET AUX CODES LOCAUX EN VIGUEUR

## **8 - TROUBLESHOOTING**

### Troubleshooting



### **WARNING**

Electrical shock hazard. Turn OFF electrical power supply at man power switch before servicing unit. Service shall be performed by a qualified service agent Failure to do so could result in death or serious injury.

#### 1. Error Codes

**Table 6 - Universal Control Error Codes And Troubleshooting**

Display on Master Control	Possible Cause	Corrective Action
Fuse LOW Voltage M1, M2, M3, M4	Low in coming power on terminals L and N (< 104 Vac)	Contact electrician or local power company to correct. Power should be between 104 Vac and 127 Vac.
	Low volt fuse (PTC Open) See Control Layout	The low volt PTC fuse is an auto reset device and is non replaceable. Should it remain open, replace the control.
	Voltage on terminals R and C less than 18 Vac. Transformer faulty or overloaded.	Check for possible shorts or faults in external low volt wiring. Check for excessive external loading from thermostats or other low volt devices. Replace, remove or correct problem.
Voltage High M1, M2, M3, M4	Voltage > 32 Vac	Check that incoming power is less than 127 Vac. Contact electrician or local power company to correct. Check transformer Low Volt Power at terminals R and C. If greater than 32 Vac while incoming power is less than 127 Vac then replace transformer.
Voltage Low M1, M2, M3, M4	Voltage < 18 Vac	Check that incoming power is greater than 104 Vac. Contact electrician or local power company to correct. Check transformer Low Volt Power at terminals R and C. If less than 18 Vac while incoming power is greater than 104 Vac then replace transformer.
*ZC Hold 1 – 15 (Flash) *Note: ZC Hold may display periodically as part of normal operation.	ZR-ZC Interruption	Check wiring between Universal control and boiler controller
	Boiler water temperature is below minimum	Check for correct boiler operation. Correct as needed.
Zone Valve Fail 1 – 15 (Flash)	Zone Valve fail to close terminals 3 & 4	Check valve wiring.
	Faulty valve	Replace zone valve
	Jumper missing between terminals 3 & 4 (2-wire zone valve only)	Add jumper wire on zone valve terminals 3 & 4
Comm Error	Communication error between master and expansion	Check communication wire between master control and expansions modules. Replace if faulty.
		Check transformer power at terminals R and C is 18-30 Vac.

## **8 - TROUBLESHOOTING**

**Table 6 - Universal Control Error Codes And Troubleshooting**

Display on Master Control	Possible Cause	Corrective Action
Too Many Exp Modules	Exceeded maximum allowable expansion modules	Reduce number of expansion modules to allowable number. See Sequence of Operation – Expansion Port.
Display is blank	No incoming power	Check field circuit breaker.
	On board fuse is open	Check for possible short circuits in pump connections. Check for faulty pump(s). Check for excessive pump loads. The total pump load for each control should NOT exceed maximum specifications.

## **9- REPLACEMENT PARTS**

Part Description	Part Number
18" Telephone cable connector	RJ45
Field-mounted 40 VA transformer (UZ3)	119000002
Field-mounted 40 VA transformer (EZ1)	240010835

## **10 - TECHNICAL SUPPORT**

Contact ECR International Technical Service 1-800-325-5479 for technical support for Argo products.

Have model number available when calling.

### **Information Needed When Calling**

Model Number
Installation Date
Installer



**ECR** international

2201 Dwyer Avenue, Utica, NY 13501

Tel. 800 253 7900

www.ecrinternational.com

All specifications subject to change without notice.

©2018 ECR International, Inc.