

Enjoy full control of your comfort with a **CONFORTO** Electric furnace



WHY CHOOSE GRANBY'S ELECTRIC HEATING PRODUCTS?

In addition to Granby's renowned expertise, there are many additional significant advantages.



Guaranteed Comfort

Modulation function maintaining desired ambient temperature at all times.



Versatility

Full range of models and heating capacities available.



Peace of mind

Granby provides a 5-year parts warranty.



Advanced technology

Software defined electronic controls compatible with today's smart thermostats. Readily adaptable to several configurations of heating and / or air conditioning.



Optimized energy consumption

Our furnaces have functions minimizing their electricity consumption, which means savings for the consumer.



Low environmental footprint

Electricity is a renewable source of energy and safe for the environment.

What sets us apart

CONFORTMAX MODULATION

Our ConfortMax modulation system is intelligent, which means it analyzes every heating cycle in real time and adapts its heating output accordingly.

What does that change?

- Ensures a more linear ambient temperature at all times and prevents undesired temperature swings.
- Reduces the amount of energy consumed by the appliance.
- Eliminates short cycling which increases the durability and long term reliability of the electric components.

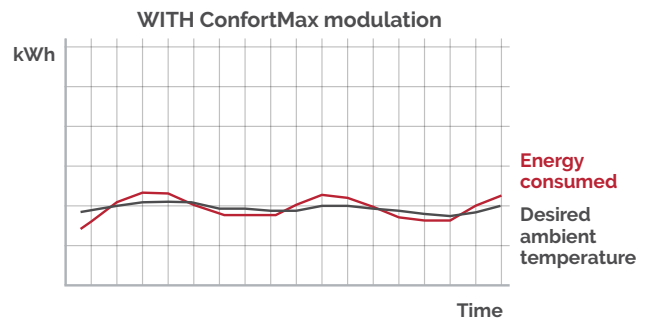
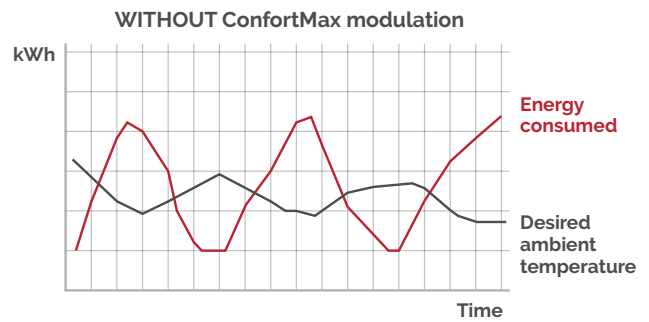

QuietComfort functionality



WITHOUT QuietComfort

WITH QuietComfort

- Warmer than desired temperature
- Desired temperature
- Cooler than desired temperature

EXCLUSIVE AT GRANBY INDUSTRIES

When activated, the QuietComfort feature allows continuous recirculating air from the furnace to be preheated at low energy. The function is automatically deactivated at night (when night temperature setback is activated) and reactivated automatically when heat demand is required.

What does that change?

- Provides more even ambient temperature between the different floors and rooms in the home during continuous air circulation.
- Procurs greater comfort.



Simple and easy to combine to add-on central heat pump or air conditioning systems.



Appliance internal cabinet is insulated offering added benefits

- Provides a quieter operation.
- Allows for the safe installation of heating/cooling coil in the return air duct to the furnace in order to optimize its performance and offer greater comfort and savings.

Allowing you to keep control of your comfort is our commitment!

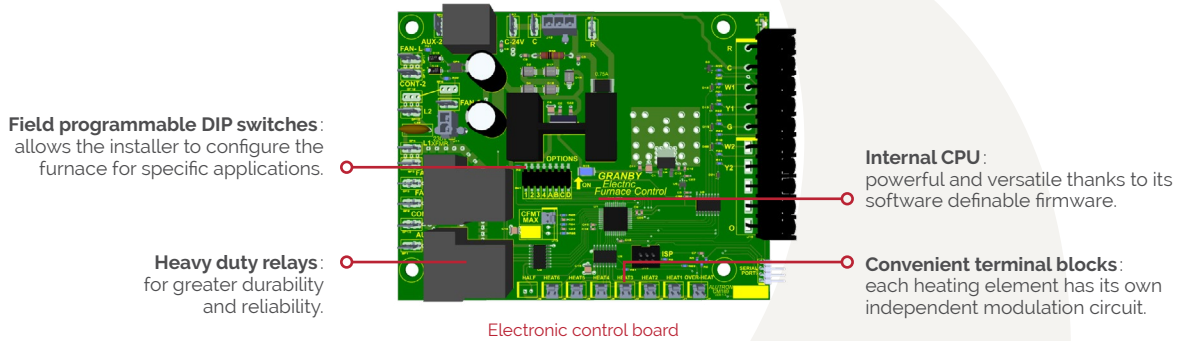

- Easy to configure at first commissioning.
- Provides up to 4 stages of heating and 2 stages of cooling.
- 24Vac connection available to accommodate HVAC accessories such as a central humidifier.
- If desired, the control will modulate the electric heating output of the furnace while running the heat pump and/or defrost cycle.
- Several operating algorithms according to the chosen location of the heat pump or air conditioner coil (supply or return).
- Possibility of running the electric furnace and the heat pump at the same time and / or during heat pump defrost periods.
- Compatible with standard thermostats and smart thermostats.

Designed for easy installation and maintenance

All connections, maintenance and access to components is available from the front of the furnace. Installation with zero clearance to combustible materials and floors.

LOWBOY WITH CENTRAL HEAT PUMP OR AIR CONDITIONER COIL

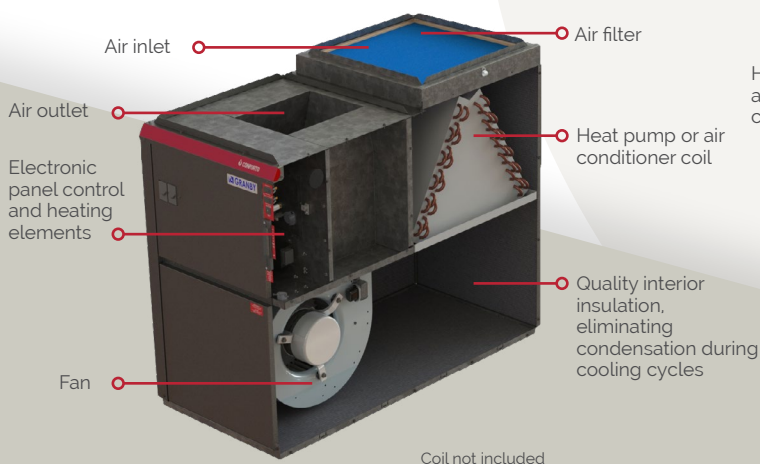

HIBOY MULTIPOSITION MULTIPOSITION WITH CENTRAL HEAT PUMP OR AIR CONDITIONER COIL

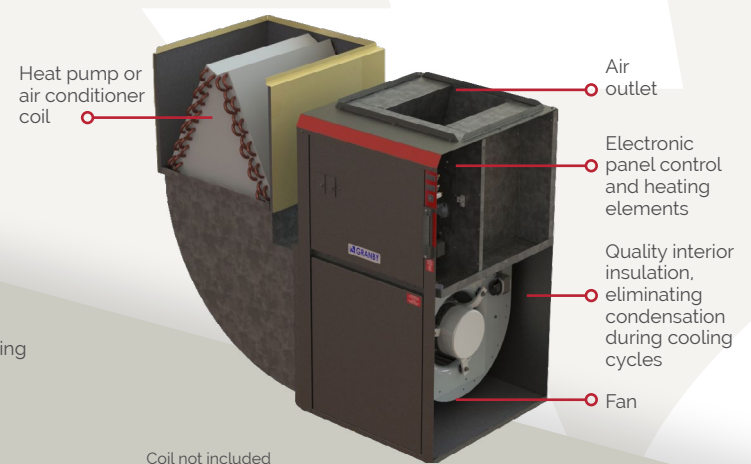

Easier and more cost effective design when converting existing LOWBOY oil furnaces. The LOWBOY model adapts very easily to the existing ventilation ducts of the oil furnace in place.

Allows an installation with a smaller footprint or multiposition installation, upflow, downflow, horizontal left or right.

Which configuration best suits you?

Conforto electric furnaces are available in 2 configurations: Hiboy Multiposition (KHE) and Lowboy (KLE).

KHE model:

- Automatic heat output modulation, ensuring a more linear ambient temperature without big temperature fluctuations.
- Efficient even in very cold weather.
- Easy installation and connections.
- Safe technology requiring little maintenance.
- Available with a PSC or ECM* fan blower motor. (the most affordable and the least restrictive ECM blower motor option available on the market), both PSC and ECM blower motors are compatible with the same Granby standard electronic control.

KLE model:

- Has all the advantages of the KHE model.
- Simplified installation when replacing a Lowboy oil-fired appliance.

**Renowned for their low electricity consumption and their increased life expectancy. Does not require a dedicated fan motor or proprietary electronic control. Are also eligible for certain government grants, check with your local, provincial or state authorities.*



GENERAL INFORMATION						
	KHE			KLE		
Dimensions (LxWxH)	20" x 21" x 36"			21 ½" x 44 ¾" x 34½"		
Supply Air Plenum	15" x 18"			20" x 20"		
Return Air Plenum	18 ½" x 18 ½"			20" x 20"		
Air Filter (1 included)	20" x 20" x 1"			20" x 20" x 1"		
Shipping Weight	48 KG (105 lbs.)			63,5 KG (140 lbs)		
MODELS	KHE & KLE					
Output Power (KWH)	10	15	18	20	23	27
Output Power (Btuh)	34 151	51 216	61 473	68 303	78 549	92 210
Air-Conditioning Capacity	3.0T	3.0T	3.0T	3.0T	3.0T	5.0T
Temperature Rise (F°)	35-40	50-60	60-70	65-75	65-80	50-60
Total Amps.	44	64	84	93	97	114
Volts (V/Hz/Ph)	240/60/1	240/60/1	240/60/1	240/60/1	240/60/1	240/60/1
PSC Blower Motor	240V 1/3 HP 3 speeds	240V 1/3 HP 3 speeds	240V 1/3 HP 3 speeds	240V 1/3 HP 3 speeds	240V 1/3 HP 3 speeds	240V 3/4 HP 3 speeds
ECM Blower Motor	240V 1/2 HP 5 speeds	240V 1/2 HP 5 speeds	240V 1/2 HP 5 speeds	240V 1/2 HP 5 speeds	240V 1/2 HP 5 speeds	240V 3/4 HP 5 speeds