

Pensotti H22 and V20 Flat Panel Radiators

Specification, Operation and Maintenance

General

1. Pensotti radiators are manufactured using cold rolled steel and can only be installed in forced circulation, closed loop, hydronic heating systems.
2. Series loop piping is not recommended. Homerun, 2 pipe reverse return, 2 pipe direct return and 1 pipe monoflo piping systems are preferred.
3. Pensotti H22 and V20 radiators are supplied with: hanging brackets, manual air vent and one plug.
4. Do not over pressurize the system. **Maximum operating pressure is 56 psi.**
5. Radiators can be installed in any closed loop hydromic system with operating temperatures up to 230 degrees Fahrenheit.
6. Important: **Do not install in gravity hot water or steam systems.**
7. Each radiator must be vented individually.
8. Air removal from each radiator will need to be completed upon the initial fill of the system and periodically during the heating season to assure proper operation and comfort.
9. Air removal from the system should be done while it is in a 'static' state (circulators not operating).
10. Proper air elimination will ensure adequate water flow through the radiators.
11. Radiators expand when heated. The expansion rate is .015" per linear foot when heated to 210 degrees Fahrenheit. Drilled holes and piping connected to the radiator must be able to compensate for this expansion.
12. Swing joints in the piping or flexible piping materials, are two easy ways of dealing with radiator expansion and the noises it can create.
13. Always use all the hanging brackets supplied with each radiator.
14. Hanging brackets must be secured to wall studs or proper wall backing material with appropriately sized and strength fasteners.
15. Surface temperature of the radiator will be equal to the temperature of the water flowing through it. When installed on high temperature systems use proper precautions with infants and toddlers.
16. Antifreeze use is permitted. Always refer to the boiler manufacturer's recommendations regarding type and dilution percentage.
17. Heating system water treatment is strongly suggested.
18. Do not install Pensotti radiators in harsh or caustic environments.

Maintenance

1. Routinely check for water leaks.
2. An annual test of heating system water quality is required. Specifically a pH test to determine the water's corrosive potential.
3. Systems with antifreeze must be tested annually for pH, flow point and freeze point. Follow the antifreeze and boiler manufacturers recommendation.
4. Heating system water treatment must be tested annually. Follow the chemical manufacturers recommendations.
5. Keep the external surfaces of the radiator clean using typical household cleaners and a soft rag.
6. The use of abrasive cleaners will damage the radiator's finish and void the warranty.
7. Vacuum dust and dirt from the radiator surfaces on a regular basis.
8. Touch up and nicks and scratches on the painted surfaces to minimize any surface rust from occurring.

Pensotti H22 Flat Panel Radiators

Installation Position

- Supply and return manifolds are metered with two orifices at each end of each flat tube
- Supply and return locations can be interchanged at the bottom tapping
- Always locate the manual air vent on the same side of the radiator as the return pipe
- Radiator mounting brackets must be secured to wall studs or proper wall backing material

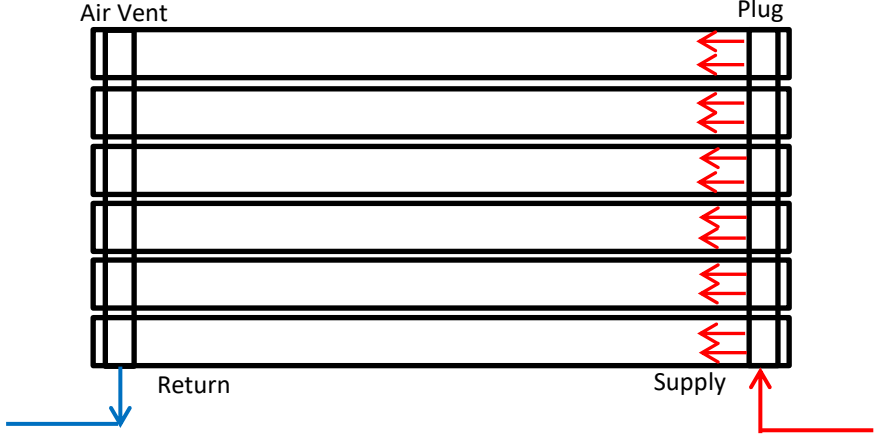
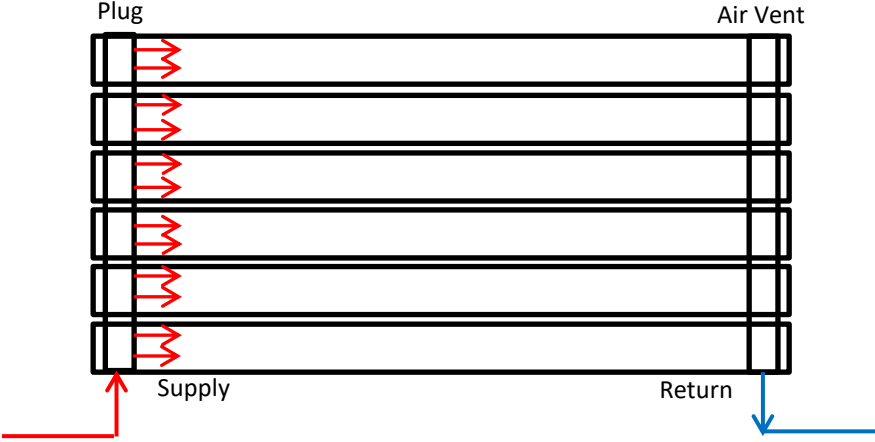

Water Flow

Pensotti H22 Flat Panel Radiators

Multi-Positional **PTKA46202B** Adapters
12mm Allen Wrench Required

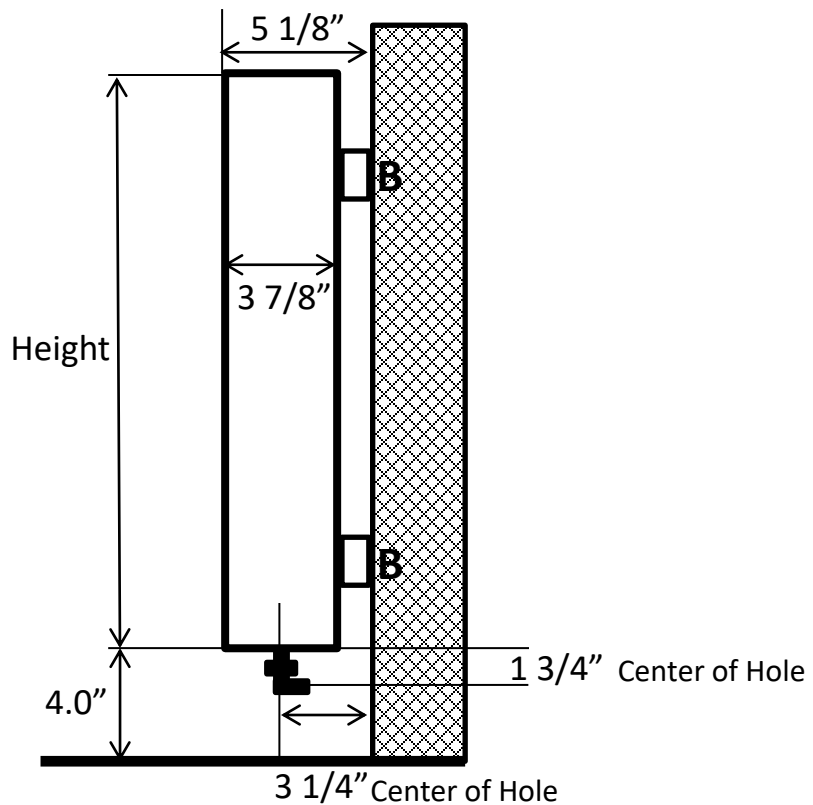
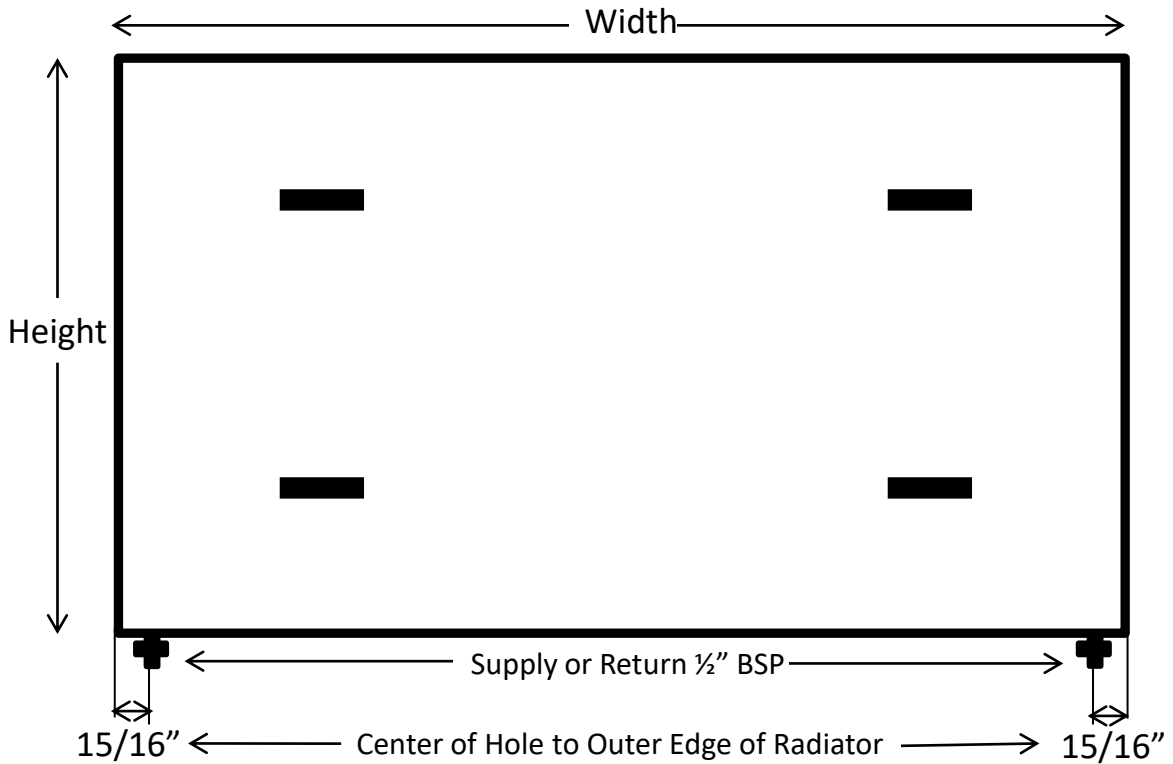

Radiator Mounting Brackets Must Be Secured To Wall Studs Or Proper Wall Backing Material

Pensotti V20 Flat Panel Radiators

Installation Position Integral Bottom Manifold Baffle

- Radiator top, designated by the manual air vent and plug, must always remain at the top
- Bottom manifold, supply and return, includes an integral baffle to encourage water flow through the entire radiator
- Supply and return locations can be interchanged at the bottom manifold
- Always locate the manual air vent on the same side of the radiator as the return pipe
- Radiator mounting brackets must be secured to wall studs or proper wall backing material

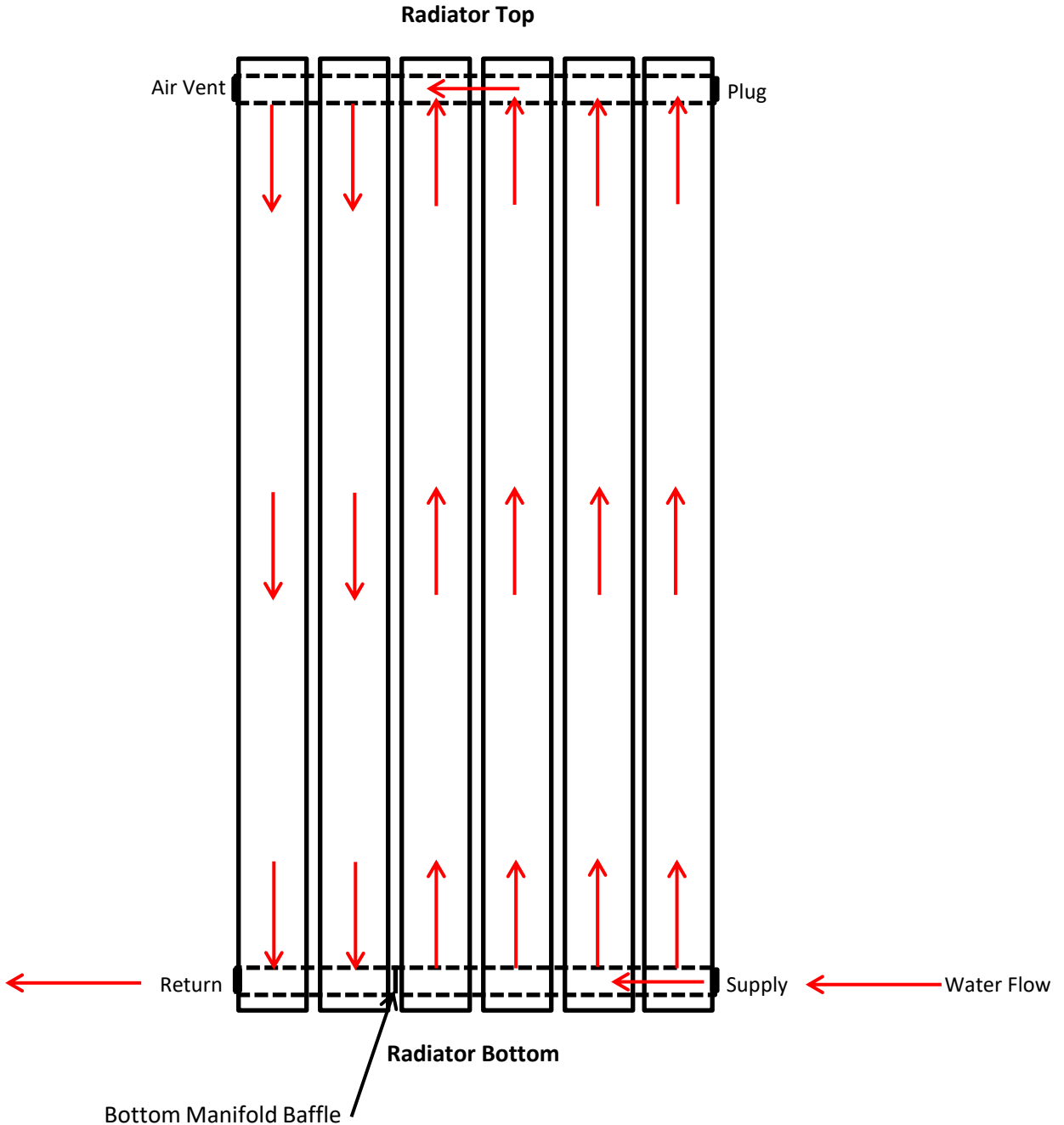

Pensotti V20 Flat Panel Radiators

Installation Position Integral Bottom Manifold Baffle

- Radiator top, designated by the manual air vent and plug, must always remain at the top
- Bottom manifold, supply and return, includes an integral baffle to encourage water flow through the entire radiator
- Supply and return locations can be interchanged at the bottom manifold
- Always locate the manual air vent on the same side of the radiator as the return pipe
- Radiator mounting brackets must be secured to wall studs or proper wall backing material

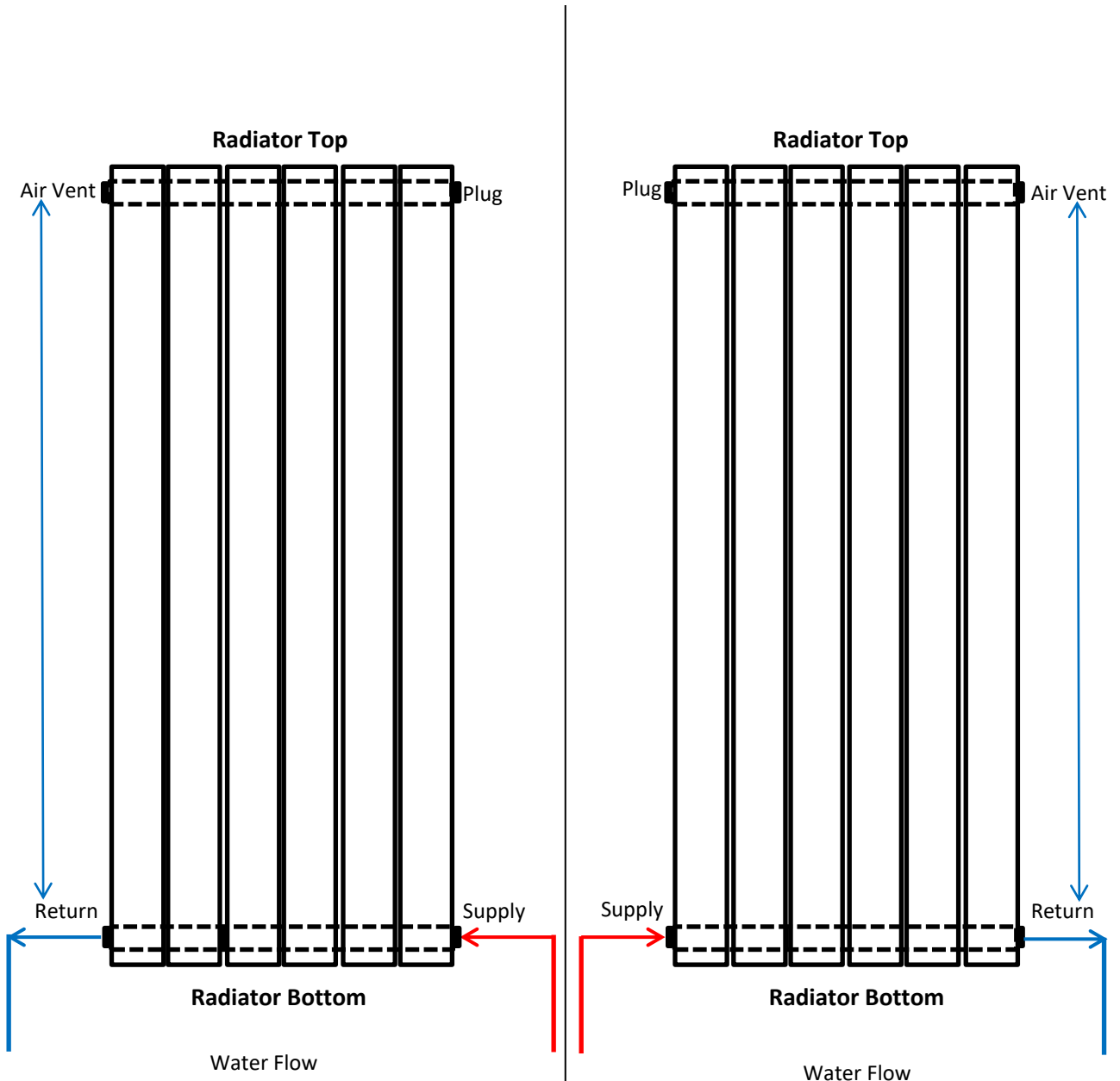

Pensotti V20 Flat Panel Radiators

Multi-Positional **PTKA46202B** Adapters
12mm Allen Wrench Required

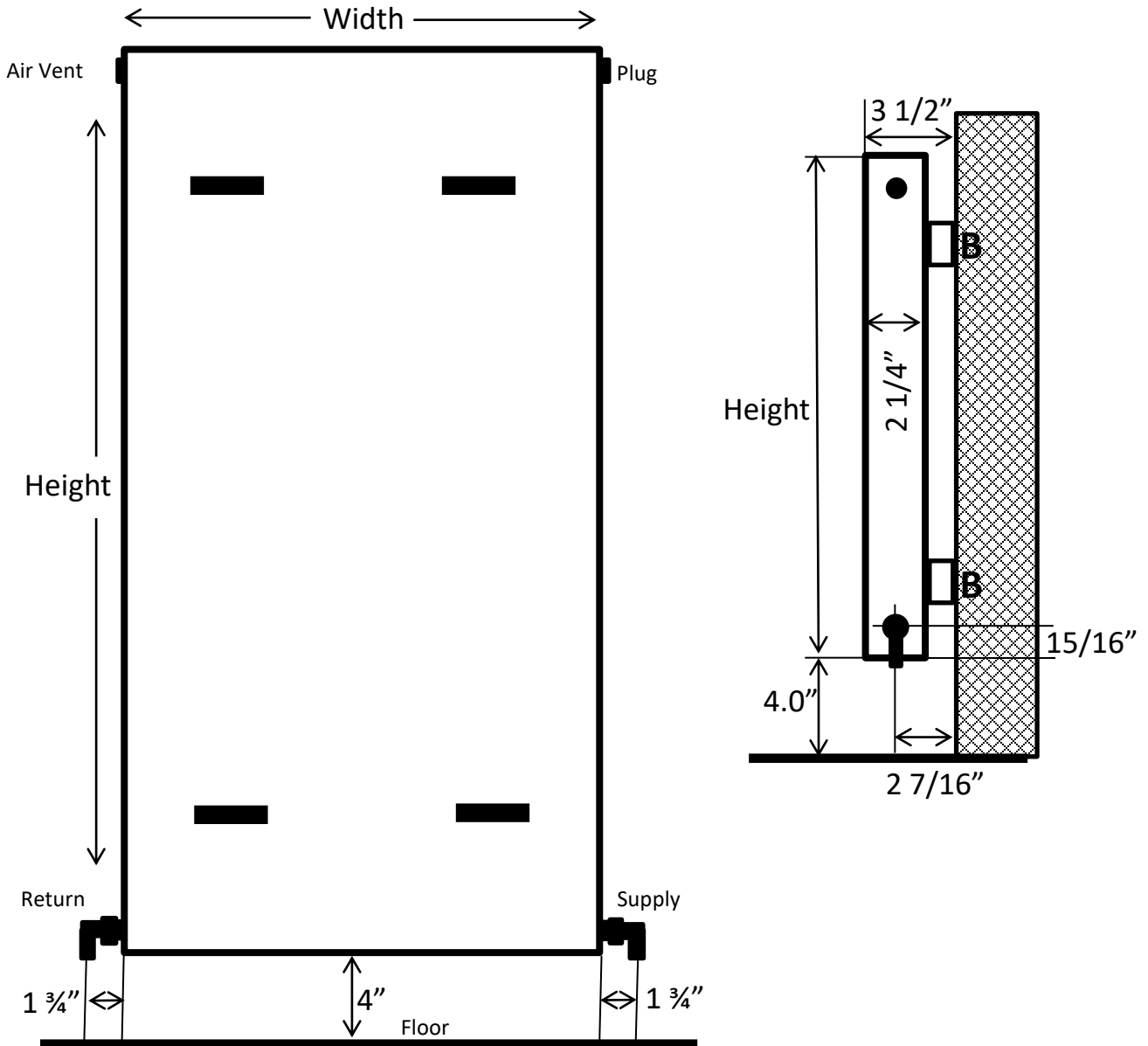

Important:

Pensotti V20 Flat Panel Radiators have a preinstalled manual air vent and plug. Their location indicates the 'top end' of the radiator.

In order for the radiator to operate properly, it must be installed with the 'top end' at the top.

In other words, the radiator cannot be turned upside down. Supply and return connections may be reversed at the bottom.

Always locate (or relocate) the manual air vent above the return connection.

Radiator Mounting Brackets Must Be Secured To Wall Studs Or Proper Wall Backing Material