

PENSOTTI

BOILERS | PANEL RADIATORS

INSTALLATION MANUAL

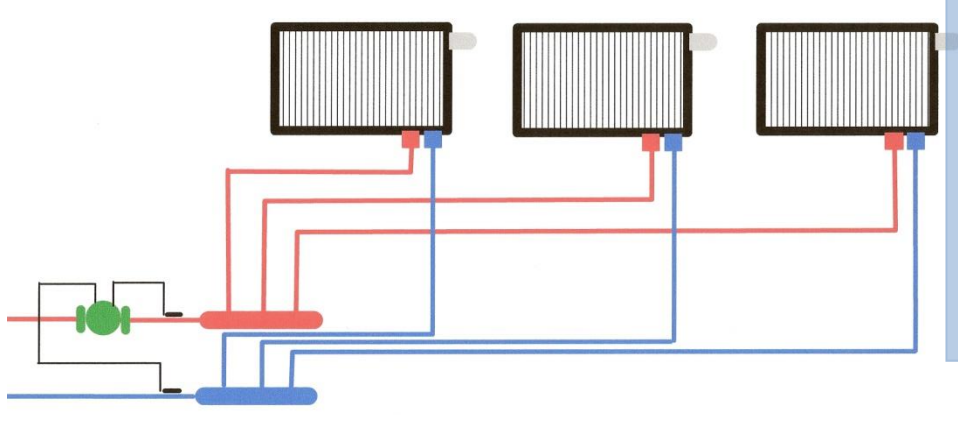

NOTE: For information or questions outside the scope of this manual contact a qualified heating professional for assistance.

TABLE OF CONTENTS

CHAPTERS

- **GENERAL DATA** page 3
- **SIZING THE RADIATOR** page 7
- **TEMPERATURE CORRECTION** page 8
- **FLOW RATE** page 9
- **PRESSURE DROP** page 10
- **ROUGH-IN** page 13
- **BRACKET & RADIATOR INSTALLATION** page 14
- **SYSTEM CONNECTION** page 15
- **THERMOSTATIC VALVE & OPTIONAL OPERATOR** page 17
- **PIPING SCHEMATICS** page 18
- **PIPING OPTIONS** page 23

GENERAL DATA

| RADIATOR MODEL | HEIGHT (in.) | LENGTH (in.) | DEPTH (in.) | BASEBOARD EQUIVALENT | BTUH OUTPUT | | WEIGHT | | |
|----------------|--------------|--------------|-------------|----------------------|-------------|-------|--------|------|----|
| | | | | | 180°F | 140°F | | | |
| HTH12-16D | 12 | 16 | 4 | 3.3 | 1934 | 1068 | 17 | | |
| HTH12-24D | | 24 | | 5.0 | 2900 | 1600 | 24 | | |
| HTH12-32D | | 32 | | 6.7 | 3866 | 2133 | 31 | | |
| HTH12-40D | | 40 | | 8.3 | 4831 | 2661 | 39 | | |
| HTH12-48D | | 48 | | 10.0 | 5800 | 3200 | 46 | | |
| HTH12-56D | | 56 | | 11.7 | 6766 | 3733 | 53 | | |
| HTH12-64D | | 64 | | 13.3 | 7732 | 4265 | 60 | | |
| HTH16-16D | 16 | 16 | 4 | 4.2 | 2418 | 1331 | 23 | | |
| HTH16-20D | | 20 | | 5.2 | 3022 | 1665 | 28 | | |
| HTH16-24D | | 24 | | 6.3 | 3626 | 1999 | 33 | | |
| HTH16-28D | | 28 | | 7.3 | 4231 | 2330 | 38 | | |
| HTH16-32D | | 32 | | 8.3 | 4835 | 2665 | 43 | | |
| HTH16-36D | | 36 | | 9.4 | 5440 | 2996 | 48 | | |
| HTH16-40D | | 40 | | 10.4 | 6044 | 3330 | 52 | | |
| HTH16-44D | | 44 | | 11.5 | 6648 | 3665 | 57 | | |
| HTH16-48D | | 48 | | 12.5 | 7253 | 3995 | 63 | | |
| HTH16-56D | | 56 | | 14.5 | 8417 | 4668 | 75 | | |
| HTH16-64D | | 64 | | 16.6 | 9620 | 5334 | 85 | | |
| HTH16-72D | | 72 | | 18.7 | 10822 | 6000 | 96 | | |
| HTH20-16D | | 20 | | 16 | 4 | 5.0 | 2876 | 1583 | 28 |
| HTH20-20D | | | | 20 | | 6.2 | 3593 | 1979 | 34 |
| HTH20-24D | 24 | | 7.4 | 4313 | | 2375 | 40 | | |
| HTH20-28D | 28 | | 8.7 | 5033 | | 2771 | 46 | | |
| HTH20-32D | 32 | | 10.0 | 5749 | | 3166 | 53 | | |
| HTH20-36D | 36 | | 11.2 | 6469 | | 3562 | 58 | | |
| HTH20-40D | 40 | | 12.4 | 7186 | | 3958 | 64 | | |
| HTH20-44D | 44 | | 13.6 | 7906 | | 4354 | 71 | | |
| HTH20-48D | 48 | | 14.9 | 8626 | | 4746 | 76 | | |
| HTH20-56D | 56 | | 17.3 | 10013 | | 5546 | 91 | | |
| HTH20-64D | 64 | | 19.7 | 11440 | | 6335 | 105 | | |
| HTH20-72D | 72 | | 22.2 | 12871 | | 7127 | 116 | | |
| HTH24-16D | 24 | 16 | 4 | 5.7 | 3310 | 1819 | 31 | | |
| HTH24-20D | | 20 | | 7.1 | 4135 | 2276 | 40 | | |
| HTH24-24D | | 24 | | 8.6 | 4964 | 2730 | 48 | | |
| HTH24-28D | | 28 | | 10.0 | 5790 | 3183 | 56 | | |
| HTH24-32D | | 32 | | 11.4 | 6619 | 3641 | 66 | | |
| HTH24-36D | | 36 | | 12.8 | 7445 | 4094 | 75 | | |
| HTH24-40D | | 40 | | 14.3 | 8270 | 4548 | 81 | | |
| HTH24-44D | | 44 | | 15.7 | 9100 | 5002 | 89 | | |
| HTH24-48D | | 48 | | 17.1 | 9926 | 5459 | 97 | | |
| HTH24-56D | | 56 | | 20.0 | 11580 | 6367 | 114 | | |
| HTH24-64D | | 64 | | 22.8 | 13235 | 7278 | 130 | | |
| HTH24-72D | | 72 | | 25.7 | 14890 | 8190 | 149 | | |
| HTH36-16D | 36 | 16 | 4 | 7.8 | 4541 | 2457 | 48 | | |
| HTH36-20D | | 20 | | 9.8 | 5678 | 3071 | 56 | | |
| HTH36-24D | | 24 | | 11.7 | 6814 | 3685 | 72 | | |
| HTH36-32D | | 32 | | 15.7 | 9083 | 4913 | 88 | | |
| HTH20-16S | 20 | 16 | 2 5/8 | 3.7 | 2171 | 1198 | 22 | | |
| HTH20-20S | | 20 | | 4.7 | 2714 | 1497 | 28 | | |
| HTH20-24S | | 24 | | 5.6 | 3256 | 1797 | 33 | | |
| HTH20-28S | | 28 | | 6.5 | 3799 | 2096 | 38 | | |
| HTH20-32S | | 32 | | 7.5 | 4342 | 2396 | 44 | | |
| HTH20-36S | | 36 | | 8.4 | 4884 | 2695 | 49 | | |
| HTH20-40S | | 40 | | 9.4 | 5427 | 2994 | 54 | | |
| HTH20-44S | | 48 | | 11.2 | 6512 | 3593 | 65 | | |
| HTH20-48S | | 56 | | 13.1 | 7598 | 4792 | 75 | | |
| HTH20-56S | | 64 | | 15 | 8683 | 4791 | 86 | | |
| HTH20-64S | | 72 | | 16.8 | 9769 | 5390 | 97 | | |
| HTH24-16S | | 24 | | 16 | 2 5/8 | 4.3 | 2497 | 1373 | 26 |
| HTH24-20S | 20 | | 5.4 | 3122 | | 1717 | 32 | | |
| HTH24-24S | 24 | | 6.5 | 3746 | | 2060 | 38 | | |
| HTH24-28S | 28 | | 7.5 | 4370 | | 2403 | 44 | | |
| HTH24-32S | 32 | | 8.6 | 4995 | | 2747 | 50 | | |
| HTH24-36S | 36 | | 9.7 | 5619 | | 3090 | 57 | | |
| HTH24-40S | 40 | | 10.8 | 6243 | | 3433 | 63 | | |
| HTH24-44S | 44 | | 11.8 | 6868 | | 3777 | 69 | | |
| HTH24-48S | 48 | | 12.9 | 7492 | | 4120 | 75 | | |
| HTH24-56S | 48 | | 15.1 | 8741 | | 4807 | 87 | | |
| HTH24-64S | 64 | | 17.2 | 9989 | | 5494 | 100 | | |
| HTH24-72S | 72 | | 19.4 | 11239 | | 6180 | 112 | | |

* Baseboard equivalent is calculated using an average water temp of 180°F @ 580 btu per ft. of baseboard. **Outputs are based upon a 24° ΔT with a room temperature of 68°F

GENERAL DATA

Pensotti Double steel panel radiators are available in five different sizes: 12, 16, 20, 24 and 36". Single steel panel radiators are available in two sizes: 20" and 24". Each size consists of multiple lengths as described in the data table below. Standard equipment with each radiator includes bottom supply and return connections with reducers, manual air vent, thermostatic valve with flow setter, white cap, two drain plugs and a set of wall mounting brackets. An assortment of PEX tubing and copper pipe fittings along with valves and accessories are available.

Pensotti Radiators are a perfect match for most hydronic heating applications and operate effectively and efficiently with both low and high temperature systems all the way up to 250° F.

The BTUH output of each Pensotti Radiator is based on the average water temperature flowing through it, along with a 24° F temperature drop across the radiator. Reduced average water temperature output tables are provided to assist in the design of high efficiency – low temperature, condensing boiler systems.

WATER CONTENT

| Height | Water Content (Gals/Foot) |
|--------|---------------------------|
| 12" | .35 |
| 16" | .40 |
| 20" | .47 |
| 24" | .54 |
| 36" | .89 |

GENERAL DATA

| Item # | Description |
|-----------------|--|
| DD10-376300 | 12" Wall Bracket Set (supplied with radiator) |
| DD10-376400 | 16" Wall Bracket Set (supplied with radiator) |
| DD10-376500 | 20" Wall Bracket Set (supplied with radiator) |
| DD10-376600 | 24" Wall Bracket Set (supplied with radiator) |
| DD10-376900 | 36" Wall Bracket Set (supplied with radiator) |
| A394-1/2"PEX | 1/2" Pex Tubing Adapter (2 pcs supplied with radiator) |
| A431-1/2"COPPER | 1/2" Copper Pipe Adapter (2 pcs supplied with radiator) |
| A55400T | 3/4"EK x 1/2" Reducer w/O-Ring Seat (2 pcs supplied with radiator) |
| V71110Q | Angle Isolation Valve w/By-Pass - O-Ring Seat (sold separately) |
| V71510Q | Straight Isolation Valve w/By-Pass & O-Ring Seat (sold separately) |
| A40400A | Thermostatic Operator w/Wax Sensor (sold separately) |
| Radsnap8W | White 8" Radsnap Pipe Cover (2 pcs supplied with radiator) |
| A56956E | White Single Pipe Escutcheon (2 pcs supplied with radiator) |

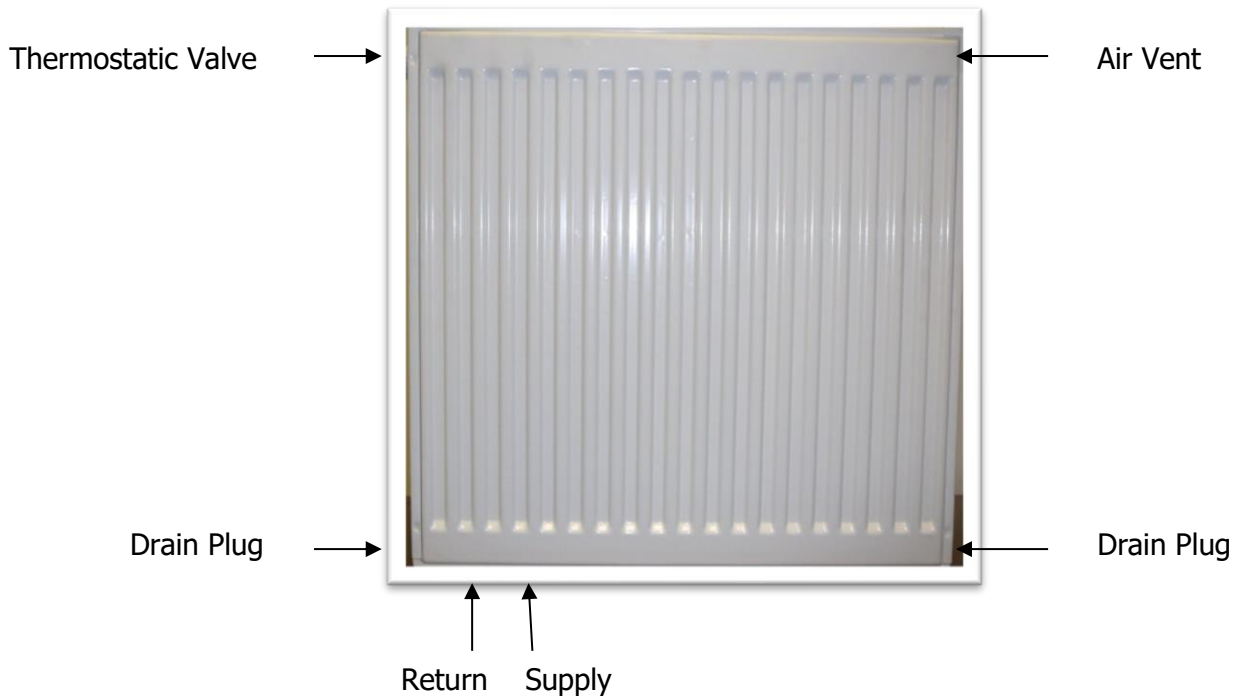

GENERAL DATA

Pensotti steel panel radiators are double panel and available in five different heights; 12", 16", 20", 24" and 36", each includes multiple lengths and heat outputs. Standard equipment with each HiTech Heat radiator kit includes:

- (2) A55400T Reducers
- (1) Manual Air Vent
- (1) Thermostatic valve with flow setter & white cap
- (2) Drain plugs (pre-installed)
- A set of mounting brackets
- (2) ½" Pex tubing fittings
- (2) ½" Copper pipe fittings
- (2) White Escutcheons
- (2) White Radsnap Pipe Covers

Radiators have a light eggshell white epoxy coated finish which, if desired, can be repainted by an automobile refinishing professional to a color of your choice.

Each radiator is manufactured with six ½" BSP threaded connections, as shown in the picture on the previous page, one of which has a factory installed integral thermostatic valve/adjustable flow-setter, another, a manual air vent, two with drain plugs and a bottom supply and return connection with factory installed shipping plugs. Many different piping configurations are possible, examples of which will be shown later in this manual.

Pensotti Steel Panel Radiators carry a 10 YEAR warranty from the date of installation. Warranty protects the original purchaser from manufacturing defects resulting from faulty materials and/or factory workmanship.

Installation Requirements

Pensotti steel panel radiators are designed to be installed in closed hydronic heating systems, with a maximum operating temperature of 250 degrees Fahrenheit and a maximum operating pressure of 145 pounds.

If the heating system includes antifreeze the proper Ph must be maintained. High acidity will damage the radiator and void the manufacturer's warranty.

If radiators are to be installed into an existing heating system, thorough flushing of the boiler and distribution system is required. Continue flushing the system with clean water until it runs clear and debris free for several minutes. For severely dirty systems, a quality cleanser may be necessary, follow the manufacturer's instructions when using these products.

Dimensions

- Height: **12", 16", 20", 24", 36"**
- Length: **16" to 72" (see specification chart for available sizes)**
- Width: **4" (Double Rads) & 2 5/8" (Single Rads)**
- Width including mounting bracket: **5 1/4" (Double Rads) & 4 1/8" (Single Rads)**
- Bottom supply and return: **2" on center**
- Minimum clearance to floor: **4"**

-sizing the radiator

1. An accurate heat loss should be performed to determine the load of the space(s) to be heated.
2. Choose a radiator from the specification chart that most closely matches the heat loss of the space in which it is to be installed. If a single radiator does not have enough capacity, divide the load evenly into two or three radiators. (Radiator specifications on the chart are based on 180 degree F average water temperature and 68 degree F room temperature).
3. Radiators should be mounted on an outside wall.
4. Determine if the wall chosen is large enough to accommodate the radiator. If not, multiple radiators may be required.
5. Radiators must be mounted a minimum of 4" above the floor.

Water Temperature Correction

1. The radiator Btu outputs listed in the specification chart are based on standard conditions, 180 degree F average water temperature and 68 degree F room temperature.
2. Since heating systems may require water temperatures other than those at standard conditions, correction factors are provided to determine the radiator Btu output at different water temperatures.
3. Determine the system or design Delta T, the difference between the average water temperature in the radiator and the desired room temperature in degrees F.
4. Locate the calculated Delta T in the left hand column of the correction factor chart (next page). Read across to the right to determine the correction factor.
5. Multiply the radiator output (standard conditions from the specification chart) with the correction factor; the result is the corrected Btu output.

Example:

Calculated Heat Loss, 4,200 BTUs

At standard conditions, a HTH20-24D radiator, which emits 4,313 BTUs, would be chosen.

But this system requires an average water temperature 150 degrees F and a room temperature of 68 degrees F.

$$150 - 68 = 82 \text{ degree F Delta T}$$

$$82 \text{ degree Delta T} = .69 \text{ correction factor (from correction chart on page 5)}$$

$$\text{HTH20-24D} = 4,313 \text{ Btu} \times .69 = 2,976 \text{ Btu (too small to satisfy the heat loss of 4,200 Btus)}$$

Choose a larger radiator

$$\text{HTH20-36D} = 6,469 \text{ Btu @ standard conditions}$$

$$6,469 \times .69 = 4,464 \text{ Btus (which satisfies the calculated heat loss of 4,200 Btus)}$$

CORRECTION FACTOR CHART

| Delta T Average Water Temperature – Room Temperature | Correction Factor |
|---|------------------------------|
| 37 | 0.24 |
| 41 | 0.28 |
| 46 | 0.32 |
| 50 | 0.36 |
| 55 | 0.41 |
| 59 | 0.45 |
| 63 | 0.50 |
| 68 | 0.54 |
| 73 | 0.59 |
| 77 | 0.64 |
| 82 | 0.69 |
| 86 | 0.74 |
| 91 | 0.79 |
| 95 | 0.84 |
| 100 | 0.89 |
| 104 | 0.95 |
| 108 | 1.00 |
| 113 | 1.06 |
| 117 | 1.11 |
| 121 | 1.17 |
| 125 | 1.22 |
| 130 | 1.27 |
| 135 | 1.32 |
| 140 | 1.38 |

Standard Btu Output x Correction Factor = Corrected Btu Output

$$6,469 \text{ Btu} \times .69 = 4,464 \text{ Btu}$$

FLOW RATE

Flow rates for a Pensotti steel panel radiator system are based on the calculated heat loss of each heating zone. Using the calculated heat loss, determine the Btu load of each individual zone. The following formula will be used to calculate the flow rate from the Btu load of the individual zones.

$$\text{Flow Rate (GPM)} = \text{Heat Loss (Btu/h)} / 499.8 \times \text{Delta T (F)}^*$$

Delta T is the temperature difference between the supply and return of the radiators in each zone.

The following table provides several divisors for the above formula to make calculations quicker and easier.

| Delta T (F) | Divisor |
|-------------|---------|
| 10 | 5,000 |
| 15 | 7,500 |
| 20 | 10,000 |

$$\text{Flow Rate (GPM)} = \text{Heat Loss (Btu/h)} / \text{Divisor (above chart)}$$

Example 1:

Calculated Heat Loss of 23,500 Btu/h

20 Degree Delta T

$$\text{Flow Rate (GPM)} = 23,500 / 20 = 10,000 \text{ (above chart)}$$

$$\text{GPM} = 23,500 / 10,000$$

$$\text{GPM} = 2.35$$

Example 2:

Calculated heat Loss of 31,250 Btu/h

10 Degree Delta T

$$\text{GPM} = 31,250 / 5,000$$

$$\text{GPM} = 6.25$$

PRESSURE DROP

Radiator Pressure Drop

The following chart will be used to determine the pressure drop for each Pensotti Double Panel Radiator.

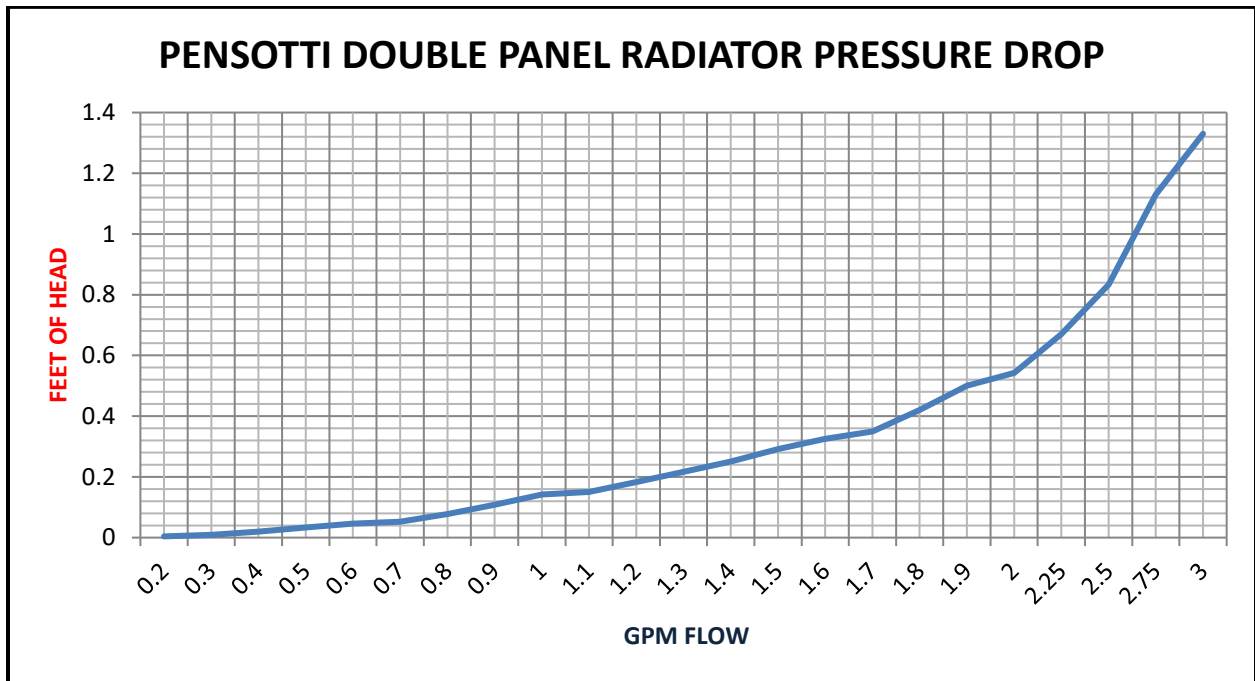

To determine the pressure drop for a radiator, first determine the gpm flow through that radiator using the flow rate formula on the previous page. Once the flow rate is determined, locate the corresponding number on the bottom axis of the chart, move straight up until you intersect the pressure drop curve, now draw a line to the left axis and read the pressure drop in feet of head. Pressure drop through radiator is based on the flow setter valve being in the full open position (position #6, see Thermostatic Valve Assembly chapter).

Repeat this procedure for each individual radiator. If the radiators are to be installed in a series circuit, add the pressure drops of each radiator together to determine the total radiator pressure drop. If the radiators are piped in a parallel circuit use the highest single radiator pressure drop as the total radiator pressure drop for that circuit.

In a series circuit the total loop flow rate passes through each radiator, in a parallel circuit the flow rate is divided among the radiators.

Example: Determine the pressure drop of a Pensotti HTH24-48D radiator, at standard conditions 9,926 Btu, with a 20 degree temperature drop.

$$\text{GPM} = 9,926 / 10,000$$

$$\text{GPM} = 0.99$$

Locate 0.99 gpm on the bottom axis of the above chart, move up to the pressure drop curve, follow the intersecting line to the left axis and read the pressure drop in feet of head, approximately .18. If this radiator was to be installed in a series circuit with 2 other radiators of the same size then the pressure drop through all the **radiators** would be $.18 \times 3$ (radiators) = 0.54 feet of head.

H VALVE PRESSURE DROP

The following chart will be used to determine the pressure drop through both styles of Pensotti radiator valves.

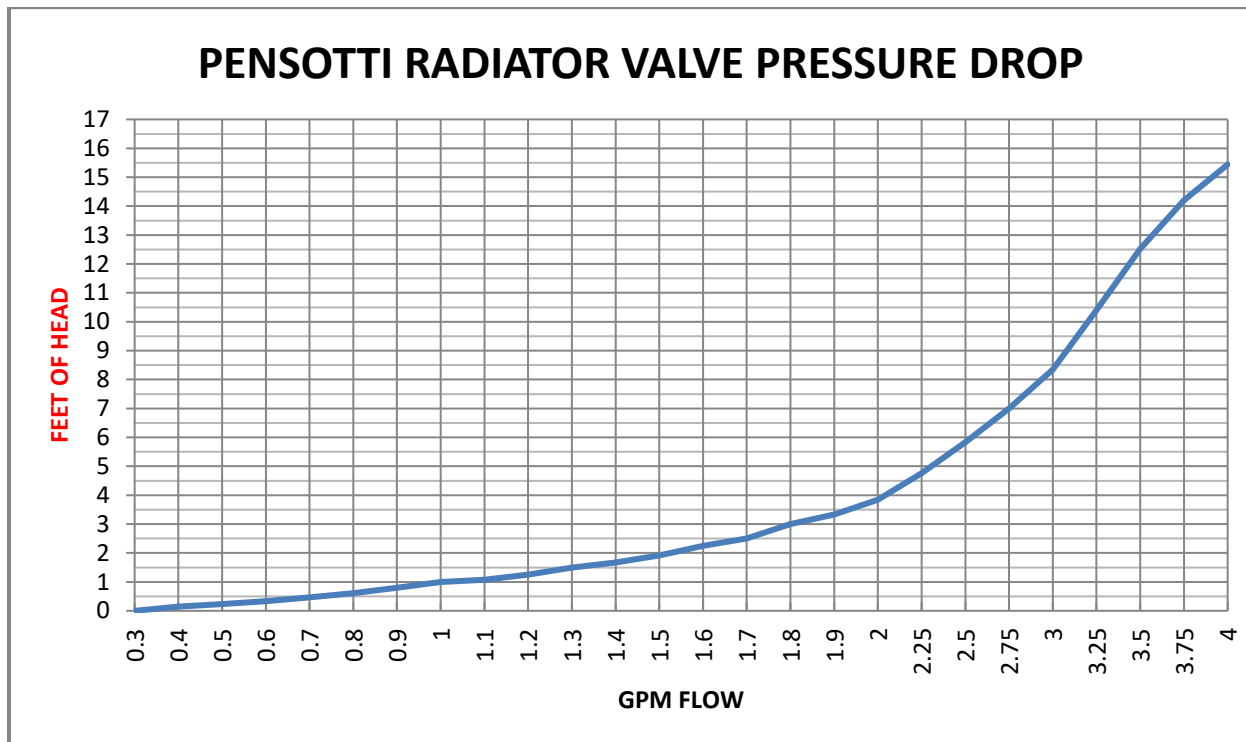

Determining the pressure drop for the radiator valve is the same procedure used for the radiators on the previous page. Find the calculated flow rate in gpm on the bottom axis of the chart, move straight up until you intersect the curve then draw a line to the left axis and read the pressure drop in feet of head.

Repeat this procedure for each individual radiator. If the radiators are to be installed in a series circuit, add the pressure drop of each valve in the circuit together to determine the total valve pressure drop. If the radiators are to be piped in parallel the valve with the highest pressure drop will determine the total valve pressure drop for that circuit.

In a series circuit the total loop flow rate passes through all the valves, in a parallel circuit the flow rate is divided among the valves.

Example:

Using the example from the previous page; a HTH24-48D radiator emitting 9,926 Btu @ 0.99 gpm flow

Find 0.99 gpm on the bottom axis of the chart, move straight up until you intersect the curve, now follow the horizontal line to the left axis and read the pressure drop for this **valve** in feet of head, approximately 1.0'.

If there were 3 of these radiators installed in a series circuit the **total valve** pressure drop would be 3 feet of head ($3 \times 1.0' = 3'$). In a parallel circuit, with the same 3 radiators, the **total valve** pressure drop for the circuit would be 1', the largest **individual valve** pressure drop in the parallel circuit.

TOTAL PRESSURE DROP

Total Piping Circuit Pressure Drop

The total circuit pressure drop is calculated by adding together the total radiator pressure drop, total H-valve pressure drop, boiler pressure drop, and the supply and return piping pressure drop (including all devices installed within the piping. (Flowcheck, aircoop, valves etc.).

Circulator Sizing

Circulator size is determined by two criteria; flow rate in gpm and total pressure drop in foot of head. After these two items have been calculated for a particular piping circuit, a circulator can be chosen using the manufacturer's performance curve.

Example;

Three Pensotti HTH12-24D panel radiators, 2,900 Btus each, installed in a series piping circuit designed for a 20 degree temperature drop.

Flow rate = $3 \times 2,900 / 10,000$

Flow rate = .87 gpm

Radiator Pressure drop = 0.108 foot of head (from radiator pressure drop chart)

H-valve pressure drop = 3 foot of head (from H valve pressure drop chart)

Boiler pressure drop = 1 foot of head (from manufacturers' information)

Supply & return pressure drop = 4.5 foot of head (calculated)

Total Piping Circuit Pressure Drop = 8.61 foot of head

.87 gpm @ 8.61 foot of head

Using the manufacturer's performance curves, choose a circulator that meets or slightly exceeds the circuits' requirements, see example below.

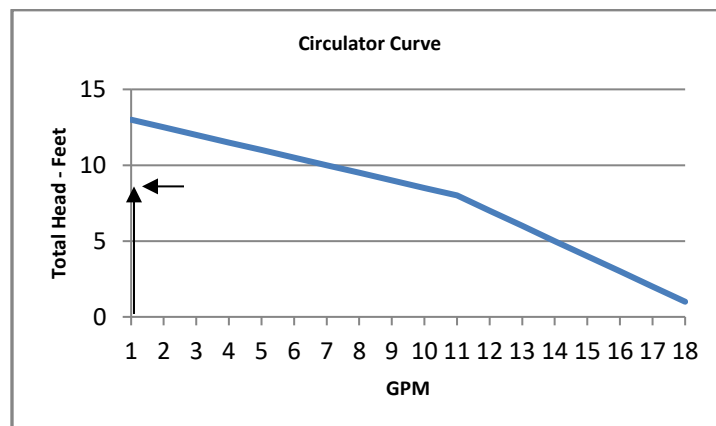

RADIATOR ROUGH-IN

Dimensions

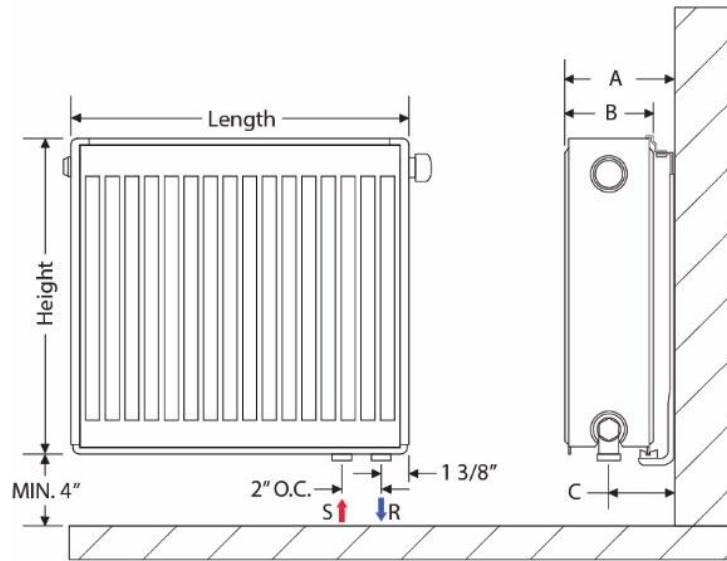

| Radiator Model | Height (inches) | A | B | C |
|----------------|------------------------|--------|--------|-------------|
| Single | 20 24 | 3 3/4" | 2 5/8" | 2 1/2" o.c. |
| Double | 12 16 20 24 36 | 5 1/4" | 4 1/8" | 3 1/4" o.c. |

Radiators should be placed on an outside wall, below a window if possible. Check the installation location and determine if adequate space is available to accommodate the panel size chosen.

Pensotti recommends the use of the bottom supply and return connections. These connections are located near the end of the radiator. The return connection is 1 3/8" from the end and the supply is 2" further in towards the radiator center. This connection location will accept both isolation valves w/bypass.

Pensotti panel radiators are reversible, dependent upon which side is facing the rooms' interior the supply and return connections may be located either on the left or right hand side. Be sure the proper connection location is selected before drilling piping holes.

See the above figure for additional dimensions and rough-in information.

The optional side connections may be used in lieu of the preferred bottom connections. Care must be taken when using these connections. In some cases, the integral thermostatic/flow-setter valve will be bypassed causing continued, uncontrolled heating of the radiator. The plugs removed from the side connections must be installed in the unused bottom connections before filling the system with water. Pensotti valves are not compatible with the side connections.

See the 'Piping Options' section of this manual for more information.

BRACKET AND RADIATOR MOUNTING

Pensotti Snap-Grip mounting brackets must be securely fastened to the wall. Frame type construction requires the brackets to be fastened to the wall studs, preferably towards the ends of the radiator. If each bracket cannot be secured to a wall stud, use 3/8" (minimum) hollow wall toggle bolt fasteners.

It is imperative that only one bracket, on any radiator, be secured with toggle bolts.

Each pair of brackets includes; 2 mounting bolts and plastic masonry anchors; do not use these anchors on frame type construction (figure 1).

Install the brackets, aligning the bottom with the desired height of the radiator bottom; a minimum of 4" is required. Plumb the brackets against the wall and mark the screw locations. Drill pilot holes, install the screws (don't tighten to the wall), hang the brackets from the screws and tighten completely.

Extend the top clamp by pulling the nylon thumb retainer towards you approximately 1/4" of an inch while lifting up on the top clamp, repeat for all brackets. Lift the radiator and angle the bottom towards the wall, set the inside water panel into the nylon bottom bracket (figure 2). Tilt the top of the radiator towards the wall, when parallel with the wall; push the top clamp down onto the top rear of the radiator until a click is heard (figure 3). An adjustment screw is installed on the top of the top clamp; this permits minor adjustments to the clamp location if necessary (figure 3).



Figure 1

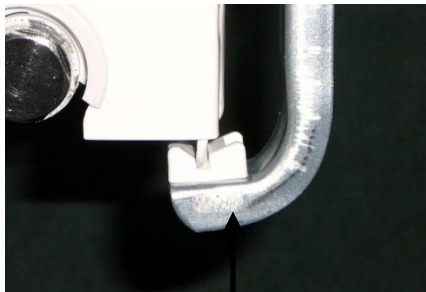

Figure 2



Figure 3



Figure 4

SYSTEM CONNECTION

Pensotti panel radiators may be connected directly to the system piping using the available pex tubing and copper pipe adapters (Figure 1). Isolation By-pass valves are also available and are installed between the radiator and aforementioned tubing or pipe adapters (Figure 2).

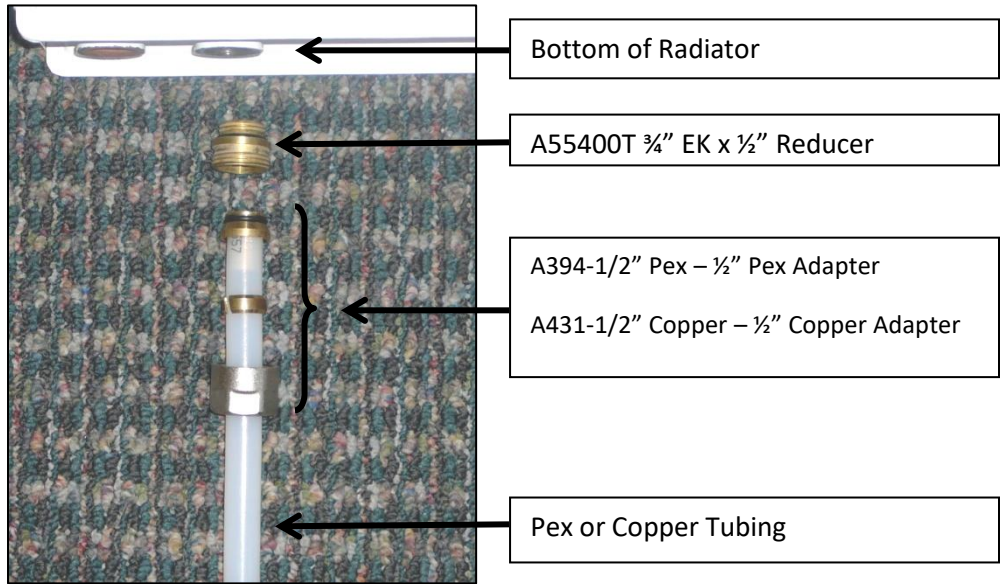

Figure 1

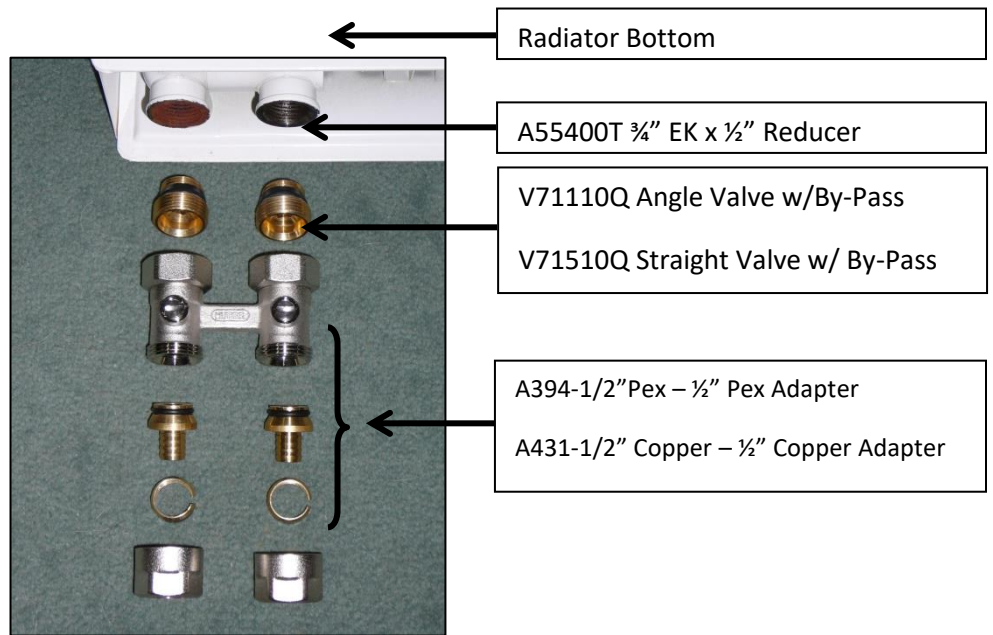

Figure 2

Figure 1 Pex: Insert the A55400T reducers into the supply and return connections of the radiator and tighten with a 12mm allen wrench. Choose the proper size pex tubing adapter assembly, slide the nut onto the tubing followed by the compression ring, then firmly press the insert into the tubing until it bottoms out. Slide the nut and compression ring onto the A55400T reducer and tighten.

Figure 1 Copper: Insert the A55400T reducers into the supply and return connections of the radiator and tighten with a 12mm allen wrench. Slide the A431-1/2" Copper adapter (one piece) onto the copper pipe until the pipe end contacts the lip on the inside of the rubber seal. Attach to the A55400T reducer and tighten.

Figure 3: Installation using valves is the same as described above. The only difference is the addition of one of the valves between the A55400T reducer and tubing or pipe adapter.



V71510Q - Straight By-Pass Valve

By-Pass valves, both straight and angle, are preset to 35% flow through the radiator and 65% through the by-pass. Maximum circuit flow rate must **not** exceed 2 GPM when using either the straight or angled By-Pass Valves. A maximum of 4 radiators may be connected to a By-Pass Valve piping circuit.

If the bypass function of the valve is not required:

- Remove by-pass adjustment cap (be sure not to misplace gasket under cap)
- Insert a 5mm allen wrench into bypass
- Turn clockwise until valve is seated
- Bypass is now closed
- Replace by-pass adjustment cap and gasket

Be sure to check all fittings and connections before filling the radiator(s) and again after radiators are heated for the first time.

THERMOSTATIC VALVE ASSEMBLY & OPERATOR

Integral Thermostatic Valve and Flow Setter Assembly

Pensotti panel radiators have integral thermostatic and flow setter valves installed as standard equipment, thermostatic operators are optional.

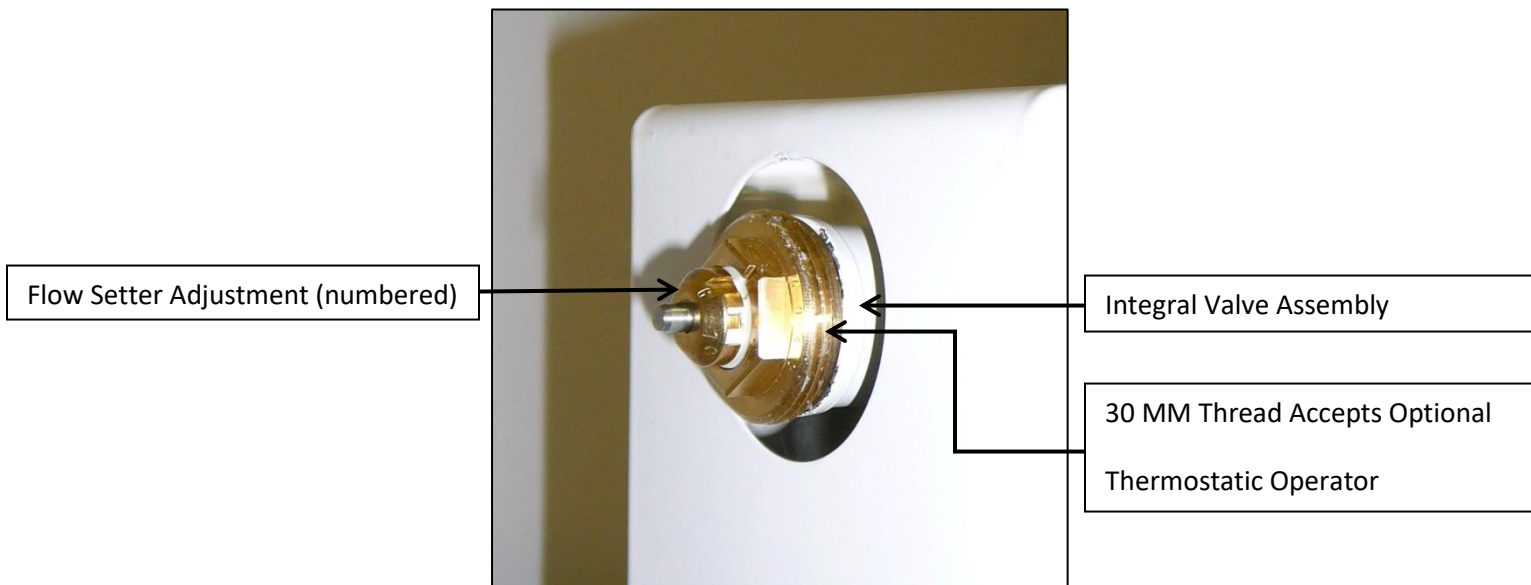

Flow Setter is adjusted by turning the inner gland (picture above) to the corresponding number.

| Number | Percentage Open |
|--------|-----------------|
| 1 | 10 |
| 2 | 20 |
| 3 | 30 |
| 4 | 40 |
| 5 | 50 |
| 6 | 100 |

As the flow setter valve opening is reduced the pressure drop (resistance) through the radiator will increase. Considering the additional pressure, circulator performance may need to be re-assessed.

Optional Thermostatic Operator Settings

| Number | Approximate Room Temperature |
|-----------|------------------------------|
| Snowflake | 44 F |
| 1 | 52 F |
| 2 | 61 F |
| 3 | 68 F |
| 4 | 75 F |
| 5 | 82 F |

PIPING SCHEMATICS

Water Flow

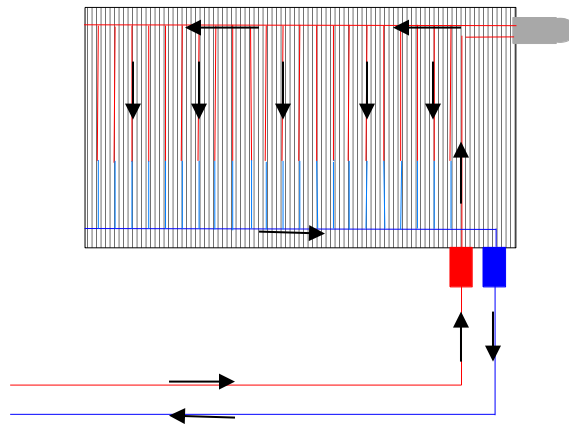

Piping schematics provided on the following pages are informational only and just a small sampling of possible piping arrangements. Sound engineering practices must be adhered to when designing any steel panel radiator heating system.

Series Circuit

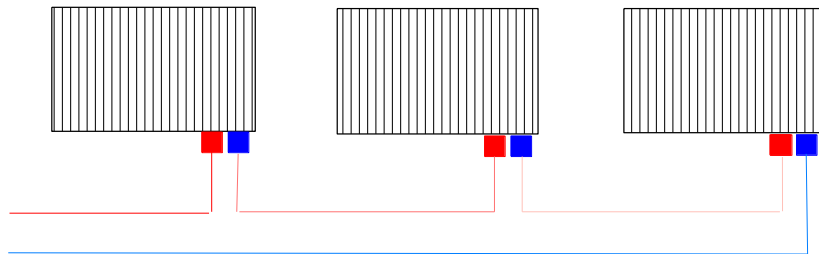

Series Circuit w/ By-Pass Valves (Maximum Circuit Flow Rate Is 2 GPM, And / Or 4 Radiators)

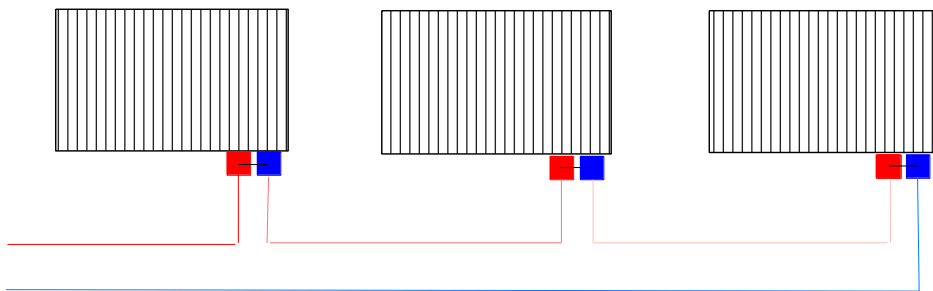

PIPING SCHEMATIC

Monoflow (Diverter Tee)

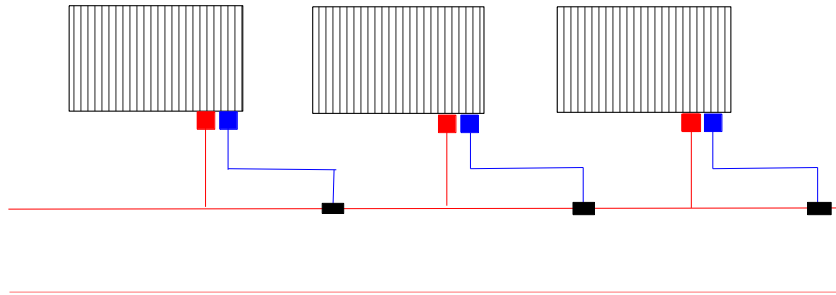

Monoflow w/Thermostatic Operators

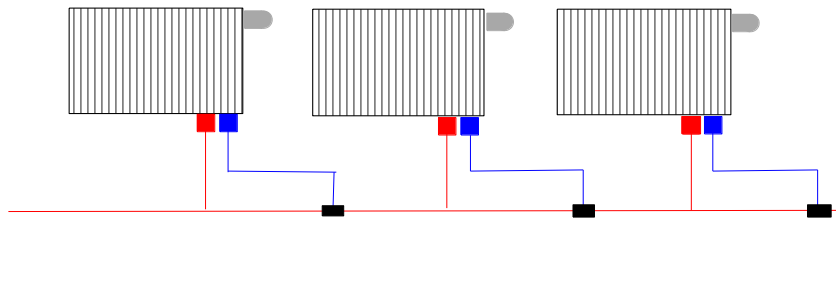

Downflow Monoflow w/ Thermostatic Operators*

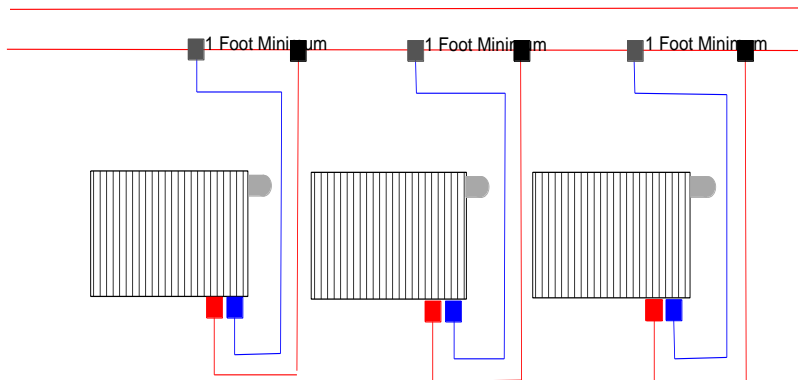

*Two monoflow tees required on each radiator

PIPING SCHEMATICS

Direct Return

(Flow Balancing Required)

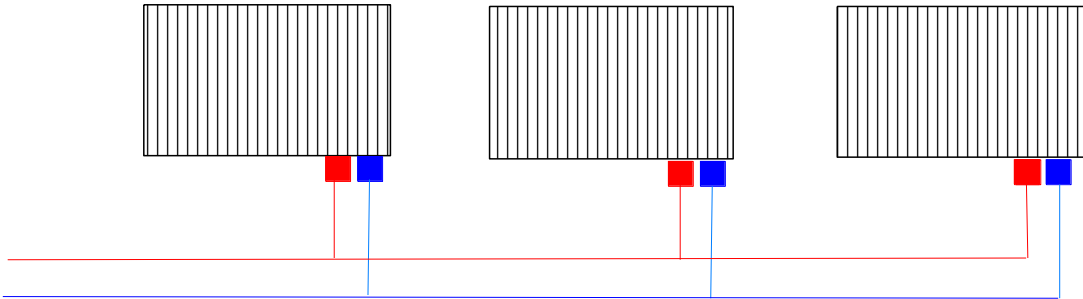

Direct Return w/Thermostatic Operators

(Flow Balancing Required)

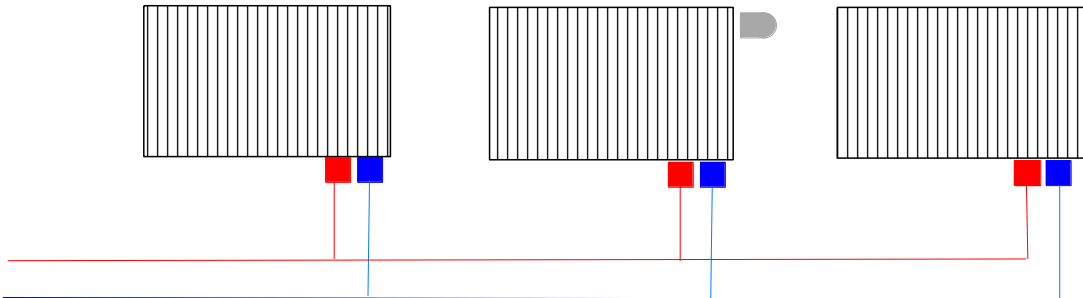

Reverse Return With or Without Thermostatic Operators

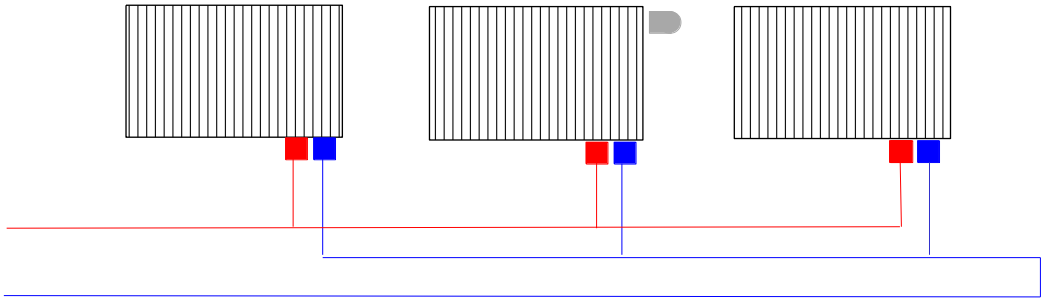

PIPING SCHEMATICS

Homerun

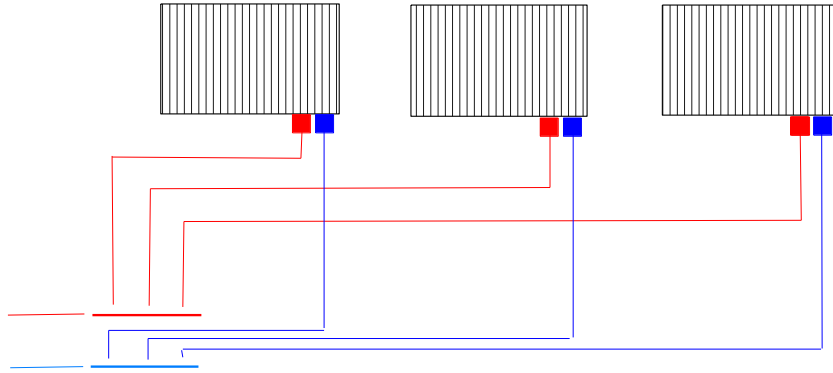

Homerun with Thermostatic Operators and By-Pass Valve

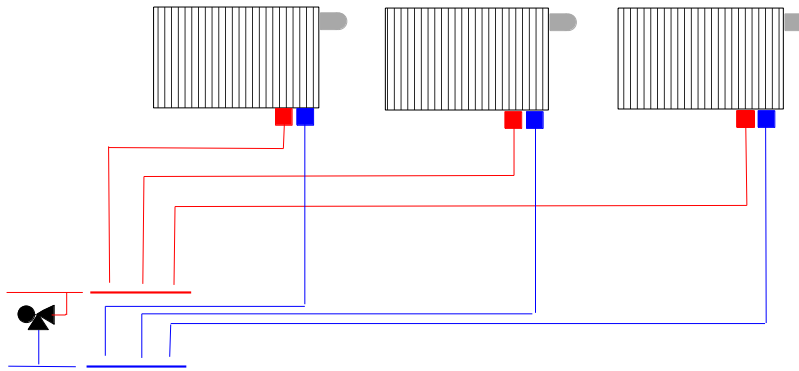

Homerun with Electric Zone Valve and By-Pass Valve

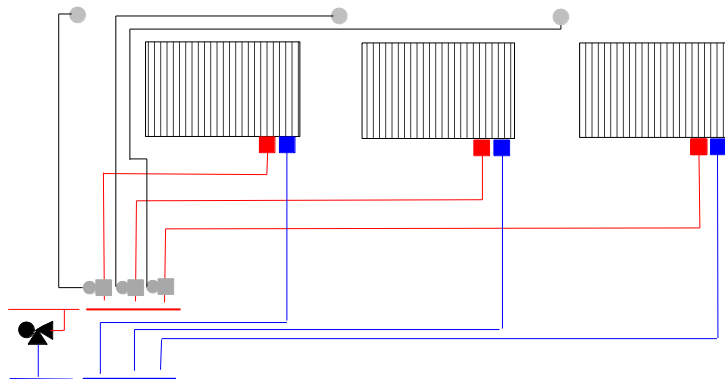

PIPING SCHEMATICS

Homerun with Thermostatic Operators and Variable Speed Delta T Circulator

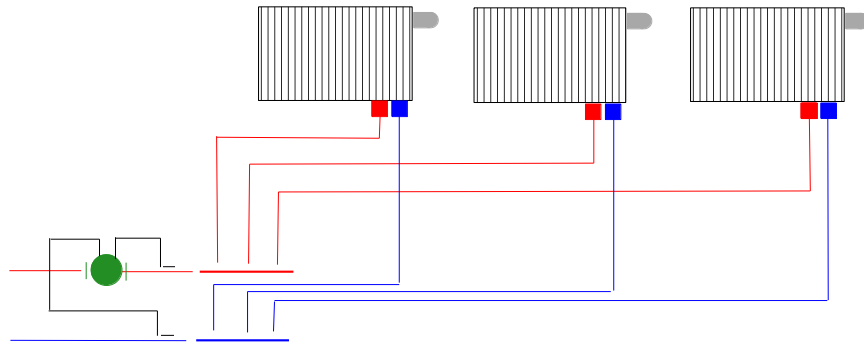

PIPING OPTIONS

Pensotti recommends their panel radiators be connected to the piping system through the bottom supply and return connections. This guarantees complete water flow through the radiator and proper operation of the flow-setter and thermostatic valve.

Should it be impossible or impractical to use bottom connections, other piping configurations are possible using the side connections. Extreme care must be used to assure proper water flow and flow-setter and thermostatic valve operation. Improper installation will result in poor system performance, reduced or no radiator Btu output, or lack of temperature control.

Pensotti isolation and diverter valves, both straight and angle, fit the supply and return connections on the bottom of the radiator only.

Alternate Piping Arrangement Examples

System designer and/or installer are responsible to determine whether proper radiator and/or system operation will result using alternate piping arrangements. Examples are provided for illustrative purposes only!

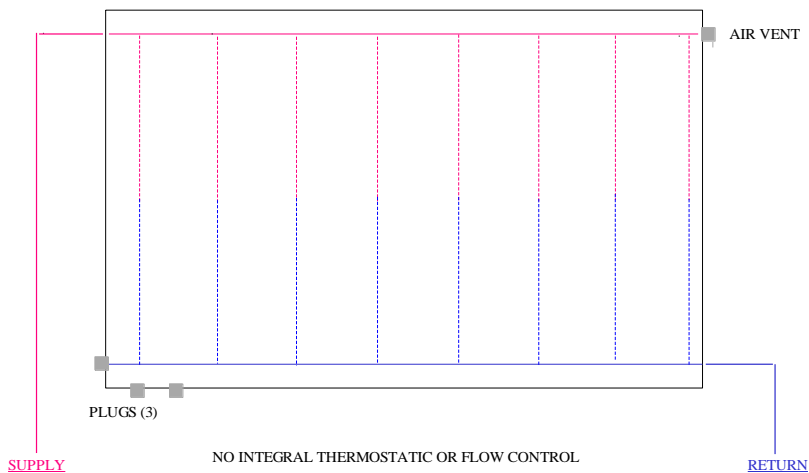

PENSOTTI PANEL RADIATORS - ALTERNATE PIPING ARRANGMENT 1

PIPING OPTIONS

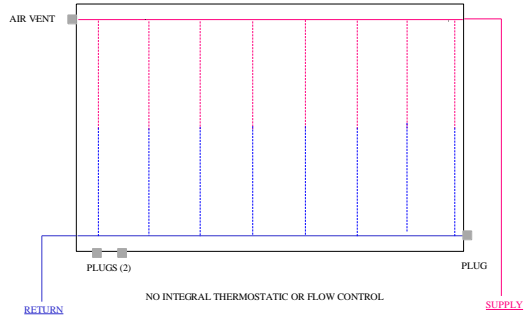

PENSOTTI PANEL RADIATORS - ALTERNATE PIPING ARRANGEMENT 2

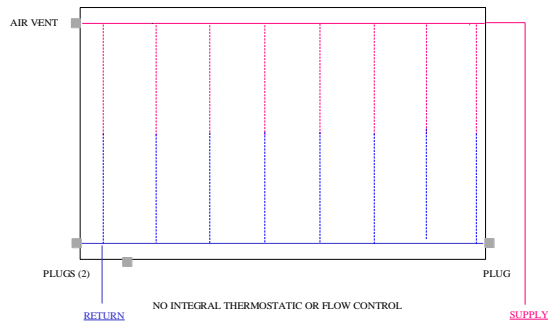

PENSOTTI PANEL RADIATORS - ALTERNATE PIPING ARRANGEMENT 3

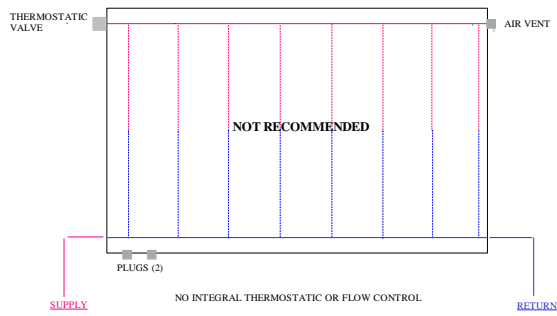

PENSOTTI PANEL RADIATORS - ALTERNATE PIPING ARRANGEMENT 4

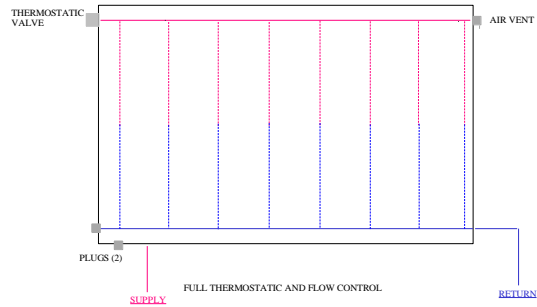

PENSOTTI PANEL RADIATORS - ALTERNATE PIPING ARRANGEMENT 4

PIPING OPTIONS

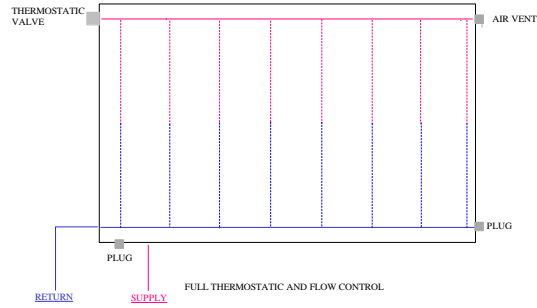

PENSOTTI PANEL RADIATORS - ALTERNATE PIPING ARRANGEMENT 5

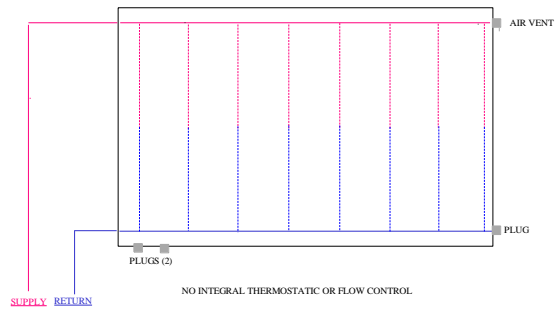

PENSOTTI PANEL RADIATORS - ALTERNATE PIPING ARRANGEMENT 6

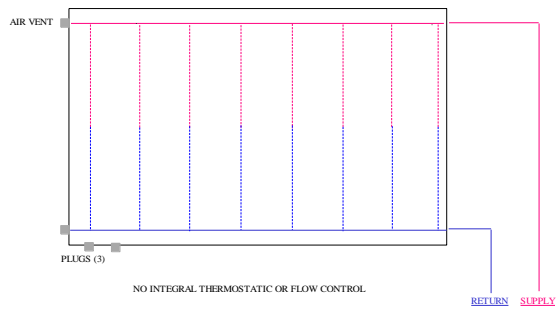

PENSOTTI PANEL RADIATORS - ALTERNATE PIPING ARRANGEMENT 7

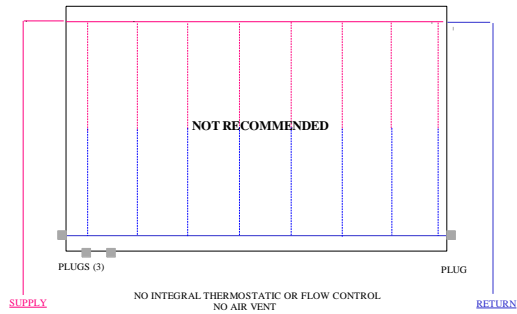

PENSOTTI PANEL RADIATORS - ALTERNATE PIPING ARRANGEMENT 4

PIPING OPTIONS

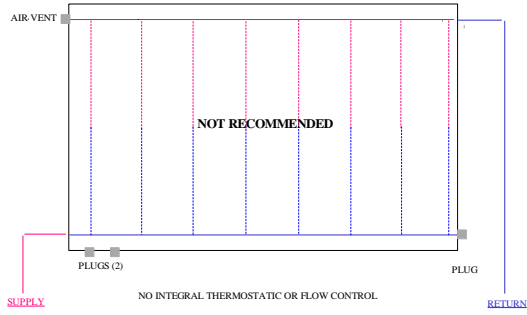

PENSOTTI PANEL RADIATORS - ALTERNATE PIPING ARRANGEMENT 4

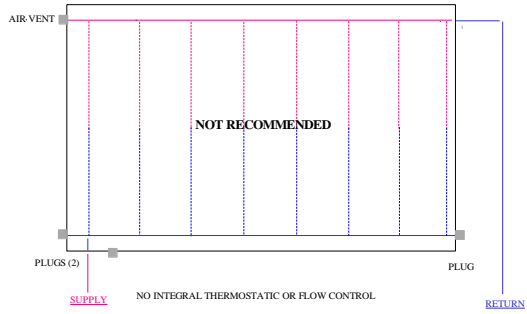

PENSOTTI PANEL RADIATORS - ALTERNATE PIPING ARRANGEMENT 4

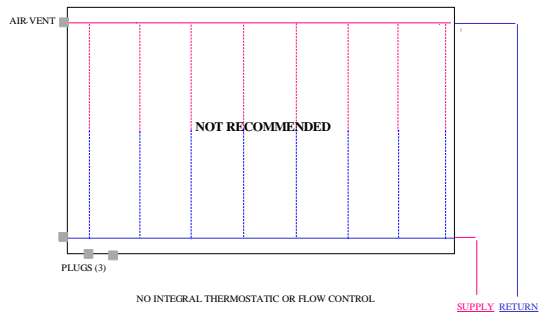

PENSOTTI PANEL RADIATORS - ALTERNATE PIPING ARRANGEMENT 4

NOTE: For information or questions outside the scope of this manual contact a qualified heating professional for assistance.

FOLLOWING PAGES INTENTIONALLY LEFT BLANK